



**2"-20"**

**MAIN LINE METERS**

**MODELS**

**ML03, ML07, ML11, ML15, ML19, ML21, MLT1**

**OPERATION AND MAINTENANCE MANUAL  
PARTS LIST**

FEATURING:

\*STANDARD TOTALIZER ASSEMBLY

\*CERAMIC BEARING CARTRIDGE PROPELLER

\* ONE PIECE SEPARATOR/SPINDLE AND THREADED REVERSE THRUST BEARING CARTRIDGE



3255 WEST STETSON AVENUE  
HEMET, CALIFORNIA 92545 U.S.A.

PHONE: 951-652-6811

FAX: 951-652-3078

VISIT OUR WEBSITE: [www.mccrometer.com](http://www.mccrometer.com)

## WARRANTY

This Warranty shall apply to and be limited to the original purchaser consumer of any McCrometer product. Meters or instruments defective because of faulty material or workmanship will be repaired or replaced, at the option of Water Specialties, free of charge, FOB the factory in Hemet, California, within a period of one (1) year from the date of delivery.

Repairs or modifications by others than Water Specialties or their authorized representatives shall render this Warranty null and void in the event that factory examination reveals that such repair or modification was detrimental to the meter or instrument. Any deviations from the factory calibration require notification in writing to McCrometer of such recalibrations or this Warranty shall be voided.

In case of a claim under this Warranty, the claimant is instructed to contact McCrometer, 3255 W. Stetson Ave., Hemet, California 92545, and to provide an identification or description of the meter or instrument, the date of delivery, and the nature of the problem.

The Warranty provided above is the only Warranty made by McCrometer with respect to its products or any parts thereof and is made expressly in lieu of any other warranties, by course of dealing, usages of trade or otherwise, expressed or implied, including but not limited to any implied warranties of fitness for any particular purpose or of merchantability under the uniform commercial code. It is agreed this Warranty is in lieu of and buyer hereby waives all other warranties, guarantees or liabilities arising by law or otherwise. Seller shall not incur any other obligations or liabilities or be liable to buyer, or any customer of buyer for any anticipated or lost profits, incidental or consequential damages, or any other losses or expenses incurred by reason of the purchase, installation, repair, use or misuse by buyer or third parties of its products (including any parts repaired or replaced); and seller does not authorize any person to assume for seller any other liability in connection with the products or parts thereof. This Warranty cannot be extended, altered or varied except by a written instrument signed by seller and buyer.

This Warranty gives you specific legal rights, and you may also have other rights which vary from state to state.

McCrometer reserves the right to make improvements and repairs on product components which are beyond the Warranty period at the manufacturer's option and expense, without obligation to renew the expired Warranty on the components or on the entire unit. Due to the rapid advancement of meter design technology, McCrometer reserves the right to make improvements in design and material without prior notice to the trade.

All sales and all agreements in relation to sales shall be deemed made at the manufacturer's place of business in Hemet, California and any dispute arising from any sale or agreement shall be interpreted under the laws of the State of California.

## MAIN LINE METER INDEX

### I. UNCRATING

### II. INSTALLATION

1. Flanged Tube Meters
2. Plain End Tube Meters
3. Welding Saddle Meters
  - A. Align
  - B. Scribe
  - C. Cut Out
  - D. Straightening Vanes
    - a.) Hold
    - b.) Mark
    - c.) Insert
  - E. Welding Saddle
  - F. Meter Assembly

### III. METER SERVICE SCHEDULE

### IV. METER HEAD ASSEMBLY

### V. WORKING AREA

### VI. TOTALIZER ASSEMBLY

1. Bonnet Mounting Screws
2. Totalizer
3. Totalizer Change Gears
4. Totalizer Drive Magnet

### VII. GEARBOX

### VIII. VERTICAL SHAFT ASSEMBLY

### IX. MITER GEAR FRAME ASSEMBLY

1. Driven Miter Gear Assembly
2. Drive Miter Gear Assembly
3. Components

### X. PROPELLER ASSEMBLY

1. Propeller Removal
2. Reverse Thrust Bearing Cartridge
3. Water Lubrication
4. Ceramic Bearing Cartridge
5. Spindle Ceramic Sleeve
6. Separator/Support Spindle Assembly
7. Propeller Installation
8. Thrust Bearing Cartridge Assembly
9. Propeller Bearing

### XI. INSPECTION

### XII. REASSEMBLY

1. Miter Gear Frame Assembly
2. Gearbox
3. Vertical Shaft Assembly
4. Totalizer Drive Magnet Assembly
5. Totalizer Base Cup
6. Bonnet Assembly
7. Propeller Assembly
8. Meter Head O-Ring

## MAIN LINE METER INSTALLATION

**I. UNCRATING.** When uncrating the meter, any damage due to rough or improper handling should be reported to the transportation firm and McCrometer. If for any reason it is determined that the unit or parts of the unit should be returned to the factory, please contact McCrometer for clearance prior to shipment. Each unit must be properly crated to prevent any further damage. The factory assumes no responsibility for equipment damage in return shipment due to improper packaging. The shipping crate contains the following items:

Main Line Meter Assembly with

Standard Totalizer.....	1
Mounting Equipment as required.....	-
Operation and Maintenance Manual.....	1
Tool T-2402X-1.....	1

**II. INSTALLATION** of McCrometer Main Line Meters varies depending upon the type and model of meter selected for each application. The meter must have a full flow of liquid for proper accuracy. The meter installations fall into three basic categories:

**1. FLANGED TUBE METERS** can be installed exactly as you would install any short length of flanged pipe. Flanged ends are standard pattern and drilling for any meter size. Fully opened gate valves, fittings or other obstructions that tend to set up flow disturbances should be a minimum of five pipe diameters upstream and one pipe diameter downstream from the meter.

**2. PLAIN END TUBE METERS** can be installed similar to replacing a short length of plain end pipe in the line by either welding, or by using one of a variety of pipe couplings available. **Note:** Meter head assembly (#13) should be removed before welding (see step IV). Fully opened gate valves, fittings, or other obstructions that tend to set up flow disturbances should be a minimum of five pipe diameters upstream and one pipe diameter downstream from the meter.

**3. WELDING SADDLE METERS** can be installed on an existing pipeline by cutting a hole of proper size and welding a meter saddle (furnished with the meter) to the pipe. The installation steps outlined below should be followed carefully to achieve proper mounting of the meter:

**A. ALIGN** the cutout template in the desired position for the meter on the pipe. Make certain that the center line of the pipe and the center line marked on the template are parallel with each other. Some people prefer to use the saddle as the template.

**B. SCRIBE** the pipe along the line specified for your meter size cutout.

**C. CUT OUT** the section of pipe within the scribed line and remove all burrs, slag, and rough edges from the inside and outside of the cutout section.

**D. STRAIGHTENING VANES** are recommended when

there are less than ten pipe diameters of straight pipe (no fittings or obstructions) directly upstream from the meter location. Straightening vanes are available from the factory and, when required, should be installed in the following manner, prior to welding the saddle to the pipe:

- a.) **HOLD** the vanes on the outside of the pipe ten (10) inches upstream from the center of the cutout opening. The vanes must be parallel to the center line of the pipe and should be equally spaced radially 120 degrees apart.
- b.) **MARK** the pipe around the straightening vane bolts and drill holes for vane mounting (9/16" dia. hole for 4" through 12" meters or 11/16" dia. holes for 14" through 20" meters).
- c.) **INSERT** the vanes into the pipe through the cutout opening after installing the brass and stainless/rubber washers over the vane bolts. The brass washer should be installed against the vane bolt head with the stainless/rubber washer installed against the brass washer (rubber side away from vane). Position the vanes inside the pipe with the bolts protruding through the vane mounting bolt holes. Place stainless/rubber washers over each bolt, rubber against the pipe. The brass washer should be placed between the stainless/rubber washer and the vane mounting nut. Secure nuts to hold the vanes to the pipe (approx. 60 ft./lbs torque). The vanes can be welded to the pipe, if desired; however, the washers should not be used. **Note:** Meter head assembly (#13) should be removed before welding (see step IV).

**E. WELDING SADDLE** should be centered over the cutout section of the pipe. Make certain that no part of the pipe protrudes past the inside edge of the welding saddle. Tack weld the saddle to the pipe prior to welding a continuous bead around the saddle. **Note:** Meter head assembly (#13) should be removed before welding (see step IV).

**F. METER ASSEMBLY** should be placed in the line with the propeller nose facing the upstream flow in the pipe. Use care when installing the meter not to damage the propeller as it passes through the saddle opening. The meter head o-ring should be covered with a thin coat of grease before installing the meter. Tighten the meter head bolts securely.

#### MAIN LINE METER OPERATION AND MAINTENANCE MANUAL

**III. MCCROMETER** products have been carefully designed to be as maintenance free as possible. Periodic preventive maintenance, however, is highly recommended and should be practiced according to schedule to ensure continuous accuracy and trouble-free performance of your propeller meters. The maintenance and inspection procedure can also be used as a guide to locating a problem in the unit that may be the cause of abnormal meter operation.

Routine preventative maintenance should be performed on all meters, including cleaning and an inspection of the propeller and bearing. The interval between inspections depends on the water quality and the usage of the meter. The initial inspection should be performed after one to two years of service, to determine the period between future inspections. After five to ten years, the complete meter should be inspected to ensure years of dependable service.

**IV. METER HEAD ASSEMBLY (#13)** should be removed from the service line by removing the meter head bolts (#51) and lifting up the rear (downstream) portion of the meter head (#13) carefully pulling the assembly back (downstream) and up at the same time to allow the propeller (#38) to clear the inside of the meter saddle and be lifted free. Inspect the meter head o-ring (#50) for any sign of damage and replace if necessary. Replace the meter head assembly (#13) with a dummy cover plate if the service line is to remain in operation. **Note:** Due to the limited clearance on an 8 inch size meter a different removal procedure is used:

- a) Remove the meter head bolts (#51).
- b) Lift the meter assembly and tilt it forward.
- c) Slide the assembly back out of the saddle opening. The propeller may have to be rotated in order to fit through the saddle opening.

**V. WORKING AREA** chosen for disassembly and reassembly of the internal meter components should be clean to reduce the chance of dust or dirt particles being introduced into the meter mechanism.

**VI. TOTALIZER ASSEMBLY (#4)** service procedure should include cleaning and inspection of the unit noting any excessive wear on the change gears (#7 & #8) that may lead to operational problems in the unit.

**1. BONNET MOUNTING SCREWS (#3)** should be removed and the entire bonnet (#1) lifted off the meter.

**2. TOTALIZER** is contained within the totalizer bonnet (#1) and held in place by a base cup (#5). It should not be necessary to remove the totalizer (#4) during inspection; however, removal of the base cup (#5) is necessary for inspection of the totalizer change gears (#7 & #8). Removal of the base cup (#5) can be accomplished by inserting a small screwdriver into the two cutouts and prying upward under the edge.

**3. TOTALIZER CHANGE GEARS (#7 & #8)** should be inspected for any sign of wear. Both the A-(drive) gear and B-(driven) gear are attached to the lower portion of the totalizer assembly (#4). Spin the floating totalizer driven magnet in the center of the totalizer bottom (#4) to make certain it spins freely without bind or drag. The bottom of the totalizer has the letter "A" molded next to the A-drive gear shaft, and the letter "B" next to the B-driven gear shaft.

**4. TOTALIZER DRIVE MAGNET ASSEMBLY (#12)** located in the meter head (#13) at the top of the vertical shaft assembly (#14) should be checked and adjusted if necessary to position it 1/16 inch below the top surface of the meter head (#13). Adjustments can be made by loosening the socket head set screw in the side of the totalizer drive magnet assembly (#12), and sliding it up or down the vertical shaft (#14) as needed, using tool 1-2710. Always be sure the set screw is tightened into the flat on the vertical shaft (#14).

**VII. GEARBOX (#17)** on McCrometer meters is sealed and filled with gearbox oil to ensure the long life and proper operation of the parts contained in the miter gear frame assembly (#26). Before disassembling the lower meter assembly, the oil must be emptied out of the gearbox (#17). Vertical shaft assembly (#14) must be removed before the gearbox oil can be drained.

**VIII. VERTICAL SHAFT ASSEMBLY (#14)** is pulled directly out the top of the meter after removing two screws (#16) inside the meter head (#13). Spin the upper bearing assembly (#15) gently, checking for any sign of wear. Inspect the vertical shaft assembly (#14) to be sure it is not bent or damaged. To drain gearbox oil, turn meter over onto the meter head (#13) and drain oil into a container.

**IX. MITER GEAR FRAME ASSEMBLY (#26)** can be pulled out of the back of the gearbox (#17) after removing four screws (#36). Spin the driven magnet (#29) to make sure the unit runs freely and inspect the teeth on both the drive (#31) and the driven (#32) miter gear assemblies for any sign of excessive wear. If the assembly spins freely and the miter gears (#31 & #32) are not worn, there should be no further inspection or disassembly of the unit. Should this service procedure show that the unit does not spin freely or that the miter gears (#31 & #32) are worn, the miter gear frame assembly (#26) should be disassembled as the following steps indicate and all worn or damaged parts replaced.

**1. DRIVEN MITER GEAR ASSEMBLY (#32)** can be removed by loosening the allen head set screw, located on the side of the gear hub, and pushing the driven miter gear shaft (#34) out of the assembly. Note the location of the shim washer (#33), if any, to be sure it is repositioned properly when reassembling the miter gear frame assembly (#26). When reassembling be sure the set screws go into recess in the miter gear shafts (#29 & #34), or damage could result. Be sure clevis end of the driven miter gear shaft (#34) is at the same end as the miter gear is located or the meter will subtract from the totalizer.

**2. DRIVE MITER GEAR ASSEMBLY (#31)** can be removed by loosening the allen head set screw, located on the side of the gear hub, and pulling the driven magnet and shaft assembly (#29) out the front of the miter gear frame (#26). Note any shim washer (#33) that may be positioned behind the drive miter gear (#31) when removing the shaft (#29).

**3. COMPONENTS** of the miter gear frame (#26) as well as the gearbox (#17) should be completely inspected at this point of disassembly. Each part of the miter gear frame assembly (#26) should be carefully inspected to determine the origin of any operational problem and those parts that are damaged or worn should be replaced. Clean the parts of the unit and reassemble reversing steps (1) and (2) above.

**X. PROPELLER ASSEMBLY (#37)** inspection includes cleaning the ceramic sleeve bearing (#39), separator assembly (#18), drive magnet (#41), and the propeller assembly (#38).

**1. PROPELLER REMOVAL** Loosen the set screw (#47) in the side of the nose of the propeller. Remove the thrust bearing cartridge (#48) by turning it counterclockwise while holding the propeller in place.

**2. REVERSE THRUST BEARING CARTRIDGE (#44)** must now be removed. Turn the propeller (#37) so that the allen wrench clearance hole is lined up with the set screw in the side of the reverse thrust bearing cartridge (#44). The location of the set screw is marked by a small hole drilled in the face of the reverse thrust bearing cartridge. With a 5/64 inch allen wrench, loosen the set screw (#45) in the reverse thrust bearing cartridge (#44) two to three turns, which will allow the cartridge to be unscrewed without damaging the spindle thread. **Note:** If the bearing area appears to be clogged with dirt or sediment, making it difficult to locate the set screw (#45) or to allow the allen wrench to fit into the set screw socket, then the bearing area should be flushed out with water. Insert Tool T-2402X-1 into the propeller through the threaded nose. The tabs in the tool should engage in the screwdriver slot in the end of the reverse thrust bearing cartridge (#44). Remove the propeller assembly (#37) and reverse thrust bearing cartridge (#44) by turning Tool T-2402X-1 counterclockwise unscrewing the reverse thrust bearing cartridge (#44) from the spindle (#18). The propeller assembly with reverse flow cartridge will now slide off the spindle. **WARNING:** If the reverse thrust cartridge does not unscrew easily, it may be because the set screw was not unscrewed enough. If unscrewing the reverse flow cartridge is continued with the set screw binding on spindle thread, damage to thread could occur.

**3. WATER LUBRICATION** of the ceramic sleeve bearing (#39) is achieved by means of two openings in the end of the thrust bearing cartridge (#48) which allows air to be purged from the bearing area. These should be cleared of any foreign material by running a small wire through the holes on either side of the screwdriver slot.

**4. CERAMIC BEARING CARTRIDGE (#39)** and drive magnet (#41) should be cleaned of any foreign material and inspected for damage. Using a bottle brush, thoroughly clean the ceramic bearing surface (#39) and the magnet inside diameter (#41). After cleaning the propeller, flush the inside out with water. The outside surfaces of the propeller should also be cleaned to assure a smooth, unrestricted flow across the surface of the propeller.

Do not use an oil-based solvent in cleaning, as damage to the assembly could occur.

**5. SPINDLE CERAMIC SLEEVE (#20)** and the O.D. or surface of the separator (#18) should be cleaned and inspected for any substantial amount of wear. The thrust bearing (#48) should be checked for any damage. If it is determined that the spindle ceramic sleeve (#20) or separator (#18) are worn sufficiently, the separator/support spindle assembly (#18) should be replaced.

**6. SEPARATOR/SUPPORT SPINDLE ASSEMBLY (#18)** can be removed for replacement by removing the four mounting screws (#21) which thread into the gear box. Separator o-ring (#22) should be replaced and the new o-ring (#22) covered with a thin coat of silicone grease. The separator/support spindle assembly (#18) can then be replaced in the front of the gear box (#17) with a firm push, gently rotating the assembly at the same time. Replace and tighten the four mounting screws (#21).

**7. PROPELLER INSTALLATION** is accomplished by following these steps:

- a) The reverse thrust cartridge set screw (#45) should be protruding out of the reverse thrust bearing cartridge so it will not bind up on the spindle thread. **Note:** Look through the end of the propeller and hole in the reverse thrust cartridge to be sure the set screw is not showing.
- b) Slide the propeller assembly onto the support spindle (#18) until the reverse thrust bearing cartridge (#44) contacts the threads on the end of the spindle (#18). Using Tool T-2402X-1, thread the reverse thrust bearing cartridge onto the spindle. If you feel any resistance when threading the reverse thrust cartridge on, stop at once and check to be sure the set screw is not binding on the thread. Be careful not to cross-thread the reverse thrust bearing cartridge. Thread the reverse thrust bearing cartridge (#44) onto the spindle (#18) until the trailing edge of the propeller contacts the gear box (#17). Set the proper end play by inserting a 5/64" allen wrench into the reverse thrust bearing set screw (through the side of the propeller) and loosen the reverse thrust bearing cartridge (#44) 1/2 turn counterclockwise. Tighten the set screw in reverse thrust bearing cartridge. There should be approximately .020" clearance between the gear box (#17) and trailing edge of the propeller when the propeller is pulled forward (away from the gear box). The propeller must not contact the gear box.

**8. THRUST BEARING CARTRIDGE ASSEMBLY (#48)** should be inspected for damage and replaced in the nose of the propeller. The thrust bearing cartridge (#48) is used to adjust the amount of longitudinal end play of the propeller assembly on its spindle (#18), which should be about 1/64 inch. End play can be adjusted by turning the thrust bearing cartridge assembly (#48) clockwise until it tightens against the end of the support spindle (#18), then turning thrust bearing cartridge (#48) counterclockwise 1/8 of a turn. Tighten set screw (#47). Check the longitudinal end play of the propeller to ensure it's

not excessive and does not allow the propeller (#37) to contact the gear box (#17). Check the clearance between the propeller (#37) and gear box (#17). The clearance should be approximately .010" between the gear box (#17) and trailing edge of the propeller when the propeller is pushed back (toward the gear box). The propeller assembly (#37) must spin freely.

**9. PROPELLER BEARING (#39)** can be checked for excessive radial play by rocking the propeller (#37) gently from side to side on the spindle (#18). Some play is required for proper operation of the water lubricated ceramic sleeve bearing.

**XI.INSPECTION** of all internal meter parts that may be replaced in the field has been accomplished at this point. Should any of the meter parts, upon inspection, appear to be damaged or excessively worn, they must be replaced to ensure proper meter operation and prevent further damage.

**XII.REASSEMBLY** is necessary at this point. Before reassembling any parts, make certain that each is cleaned of any dust or dirt and properly lubricated. Costs for replacement parts not covered by warranty are available from the current parts and price list. If it is determined that the meter should be returned for repair, please notify McCrometer prior to shipment. Each meter must be properly packaged to prevent damage to the meter in shipment.

**1. MITER GEAR FRAME ASSEMBLY (#26)** can be replaced in the back of the gearbox (#17) with a firm push, gently rotating the assembly at the same time. Replace the miter gear frame o-ring (#35) and cover the new o-ring with a thin coat of silicone grease before replacing the assembly (#26). Make certain that the assembly is installed in a position such that the drive clevis portion of the driven miter gear shaft (#34) can accept the driven clevis portion of the vertical shaft assembly (#14). Secure with four mounting screws (#36).

**2. GEARBOX (#17)** must be filled with one ounce of 10w mineral oil. A small funnel or an oil can with a small nozzle will make filling the gearbox (#17) easier. Pour the oil through the opening in the top of the meter head (#13).

**3. VERTICAL SHAFT ASSEMBLY (#14)** should be inserted gently into the gearbox (#17) through the opening in the top of the meter head (#13). Rotate the shaft gently until it is engaged in the driven miter gear shaft (#34) of the miter gear frame assembly (#26). Replace and secure two screws (#16) that hold the upper bearing (#15) in place. Do not overtighten the screws (#16) as this could cock the bearing (#15) and bind the vertical shaft (#14). Turn the top of the vertical shaft (#14) to check for any bind or drag. Should any bind or drag be apparent, it can usually be corrected by adjusting the vertical shaft collar and bearing assembly (#15). Loosen the set screw (#16) in the side of the assembly (#15) and slide the shaft (#14) downward until it rests against the driven miter gear shaft (#34), then lift up about 1/64

inch. Tighten set screw (#16).

4. **TOTALIZER DRIVE MAGNET ASSEMBLY (#12)** should be checked again to make certain it is properly set to drive the totalizer (#4) (see step VI, 4).
5. **TOTALIZER BASE CUP (#5)** can be placed back in the totalizer bonnet (#1) on the totalizer assembly (#4) after the desiccant capsule and the base cup o-ring (#6) are replaced. Be sure o-ring (#6) is on base cup (#5) properly.
6. **BONNET ASSEMBLY (#1)** should be cleaned and replaced on the meter head (#13). Bonnet o-ring (#2) should be replaced and the new o-ring (#2) covered with a thin coat of silicone grease. Secure with four screws (#3).
7. **PROPELLER ASSEMBLY (#37)** should be dipped in water to lubricate the propeller ceramic sleeve bearing (#39). Spin the propeller (#38) gently to make certain the meter operates smoothly and no bind or drag is apparent.
8. **METER HEAD O-RING (#50)** should be inspected for any sign of damage and covered with a thin coat of silicone grease. The meter can now be installed in the service line. When replacing the meter on the line, make certain that the top of the welding saddle is smooth and free of any foreign material. Make certain that no foreign materials are attached to the inside of the service line pipe, as any flow disturbance or obstruction may affect the accuracy of the meter.

## NOTES

## 2" - 20" MAIN LINE METERS

### MODELS ML03, ML07, ML11, ML15, ML19, ML21, MLT1

### PARTS LIST

NO.	QTY.	PART NUMBER	DESCRIPTION
	1	7-MLT1-*	MAIN LINE METER HEAD ASSEMBLY
	1	6-4260	TOTALIZER & BONNET COMPLETE (ITEMS 1 THRU 6)
	1	7-4260	TOTALIZER & BONNET COMPLETE (ITEMS 1 THRU 8)
1	1	5-4316	TOTALIZER BONNET ASSEMBLY
	1	1-4317-2	TOTALIZER BONNET LID (W/PIN)
2	1	1-1551-38	O-RING, TOTALIZER BONNET
3	4	1-1115-10-10	SCREW, BONNET MOUNTING (ea.)
4	1	5-4260	TOTALIZER ASSEMBLY (SPECIFY DIAL)
	1	1-2310-‡	DIAL (AS SPECIFIED)
	2	1-1118-3-3	SCREW, DIAL MOUNTING (ea.)
	1	1-4276	SWEEP HAND
5	1	1-4318	BASE CUP, TOTALIZER
6	1	1-1551-17	O-RING, BASE CUP
7	1	3-4045	A-GEAR ASSEMBLY (SPECIFY # OF TEETH)
8	1	3-4045	B-GEAR ASSEMBLY (SPECIFY # OF TEETH)
12	1	3-2324	DRIVE MAGNET ASSEMBLY, TOTALIZER
13	1	3-2101-‡‡	METER HEAD (SIZES 2" THRU 12")
	1	2-2101-14	METER HEAD (SIZES 14" THRU 20")
14	1	2-2520-*	VERTICAL SHAFT
15	1	3-2352	VERTICAL SHAFT COLLAR & BEARING ASSEMBLY
16	2	1-1113-6-4	SCREW, VERTICAL SHAFT COLLAR & BEARING MTG. (ea.)
17	1	2-2238-*	GEARBOX
18	1	4-2455-2	SEPARATOR/SUPPORT SPINDLE ASSEMBLY
20	1	1-1508-20	CERAMIC SLEEVE FOR SUPPORT SPINDLE
21	4	1-1103-8-7	SCREW, SEPARATOR/SPINDLE MOUNTING (ea.)
22	1	1-1551-24	O-RING, SEPARATOR/SPINDLE
23	1	10110-10	O-RING, GEARBOX
24	4	1-1251-5-12	BOLT, GEARBOX MOUNTING (ea.)
25	-	1-1806	VIBRA-TITE, GEARBOX MOUNTING BOLT
26	1	4-2347	MITER GEAR FRAME ASSEMBLY (ITEMS 27 THRU 35)
27	1	2-2347	MITER GEAR FRAME
28	4	1-1504-2	BEARING, MITER GEAR FRAME (ea.)
29	1	3-2348	DRIVEN MAGNET & SHAFT ASSEMBLY
30	1	1-2354-P	DRIVEN MAGNET SPACER
31	1	3-2349	DRIVE MITER GEAR ASSEMBLY
32	1	3-2137	DRIVEN MITER GEAR ASSEMBLY
33	2	2-2148-1	SHIM WASHER (ea.)
34	1	2-2138	DRIVEN MITER GEAR SHAFT
35	1	1-1551-2	O-RING MITER GEAR FRAME
36	4	1-1103-8-7	SCREW, MITER GEAR FRAME MOUNTING (ea.)
37	1	5-2425-‡-PT	PROPELLER ASSEMBLY (ITEMS 38 THRU 48)
38	1	3-2425-‡-P	PROPELLER
39	1	2-2426-P-1	CERAMIC BEARING CARTRIDGE ASSEMBLY
40	1	1-1116-8-6	SCREW, CERAMIC BEARING CARTRIDGE MTG.
41	1	2-1601-2	DRIVE MAGNET
42	1	1-2428-‡	DRIVE MAGNET RETAINING PLATE
43	2	1-1115-3-18	SCREW, DRIVE MAGNET RETAINING PLATE (ea.)
44	1	3-2402-2	REVERSE THRUST BEARING CARTRIDGE ASSEMBLY
45	1	1-1101-8-5	SET SCREW, REVERSE THRUST BEARING
46	2	1-1509-1	CERAMIC THRUST BEARING, 3/16" DIA (ea.)
47	1	1-1125-6	SET SCREW, NYLON POINT
48	1	3-2356	THRUST BEARING CARTRIDGE ASSEMBLY
49	2	1-1510-1	CERAMIC THRUST BEARING, 1/4" DIA. (ea.)
50	1	1-1552-‡‡‡	O-RING, METER HEAD
51	8	1-1251-8-24	BOLT, METER HEAD (ea.)
52	8	1-1301-14	WASHER, METER HEAD (ea.)
-	-	1-1804-2-16	GEARBOX OIL (16 OZ.)
-	1	1-1607-5	DESICCANT CAPSULE

\* INSERT METER SIZE TO COMPLETE PART NUMBER

‡ CONSULT FACTORY TO COMPLETE PART NUMBER

‡‡ 2" - 8" INSERT -3 OR 10" - 12" INSERT -10

‡‡‡ 2" - 8" INSERT -1, 10" - 12" INSERT -2, 14" - 20" INSERT -3

CONSULT FACTORY FOR PRICES.

When ordering replacement parts, please specify:

● Meter Size ● Meter Model Meter ● Serial Number



**2" - 20" MAIN LINE METERS**  
**MODELS ML03, ML07, ML11, ML15, ML19, ML21, MLT1**

**\*STANDARD TOTALIZER ASSEMBLY**

**\*CERAMIC BEARING CARTRIDGE PROPELLER**

**\*ONE PIECE SEPARATOR/SPINDLE AND THREADED REVERSE THRUST BEARING CARTRIDGE**

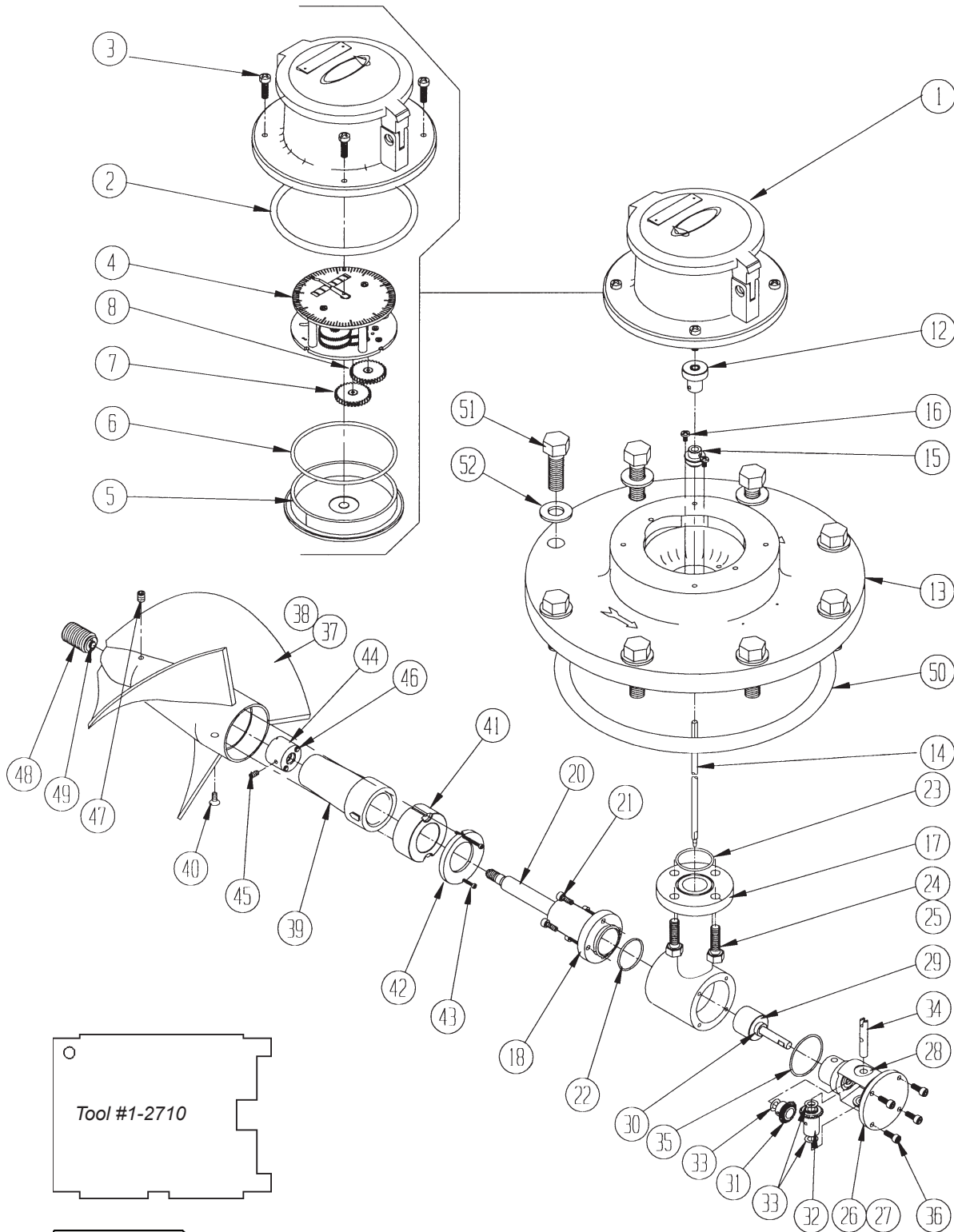

## MAIN LINE METER INSTALLATION INSTRUCTIONS

1

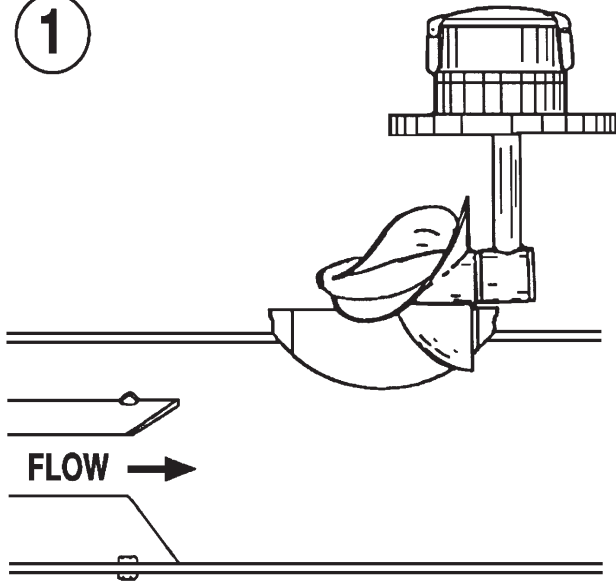

1. Set meter assembly on saddle as shown with one propeller blade pointing down. Propeller should point opposite the direction of flow.

2

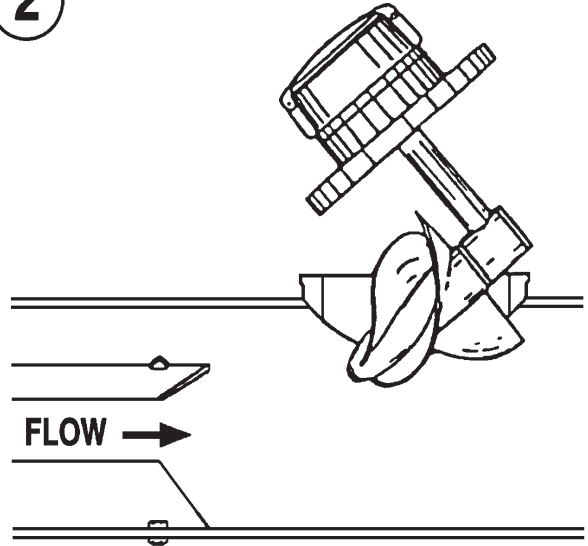

2. Tilt the meter head assembly forward allowing the propeller to move through the opening.

3

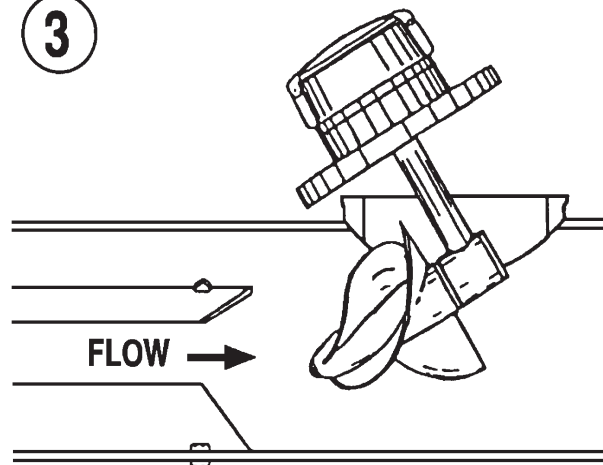

3. Slide the assembly forward and down. The propeller may have to be rotated in order to fit through the saddle opening.

4

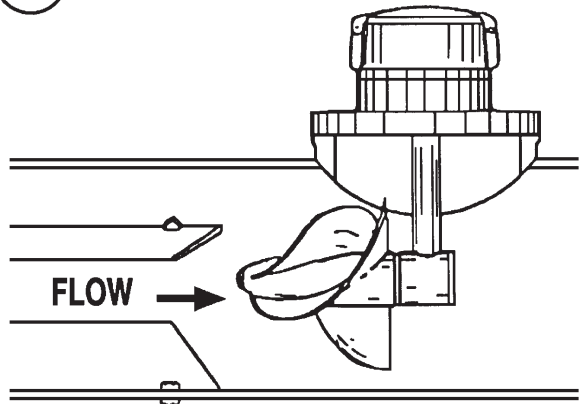

4. Allow the meter head assembly to come to rest on the saddle. Install bolts and tighten to proper torque.



**WARNING:**

**BEFORE REMOVING THE METER HEAD FROM THE PIPELINE THE WATER MUST BE TURNED OFF AND PRESSURE MUST BE RELIEVED FROM THE LINE. SERIOUS INJURY CAN RESULT FROM REMOVING A METER HEAD UNDER PRESSURE.**

**METER SHOULD NOT BE TURNED UPSIDE DOWN AS OIL WILL DRAIN OUT OF THE GEARBOX AND NOT PROVIDE PROPER LUBRICATION TO THE MITER GEARS AND BEARINGS.**