

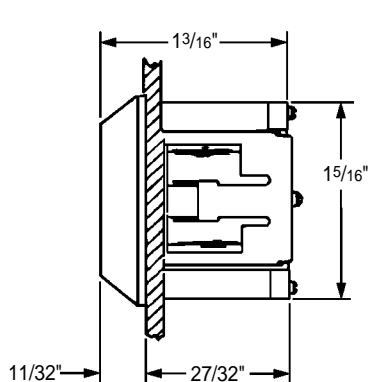

**MODEL IN16**  
 REMOTE TOTALIZER  
 SOLID STATE CONSTRUCTION  
 CONTACT COUNT- INTERNAL POWER SUPPLY

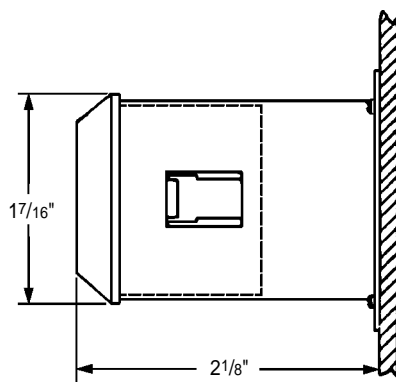

PANEL MOUNT



WALL MOUNT



## DESCRIPTION

**MODEL IN-16 REMOTE TOTALIZERS** operate in conjunction with Water Specialties Model TR04-2, TR12-2, TR28-2 or TR29-2 transmitters to provide a totalization of flow volume. The totalizer uses a counter circuit chip mounted on a gold-plated substrate and electrically connected by ultrasonic wire-bonding.

**INSTALLATION** is made through the front of an instrument panel or to any flat surface using the mounting equipment supplied. For the best operation of the system the signal line should not be run in long cable troughs or conduits with power circuits.

**CONSTRUCTION** of the remote totalizer features an o-ring sealed metal housing.

**TOTALIZER** utilizes a six digit display that is field connectable for no reset, panel reset, remote reset, or both. The remote totalizer is built using the latest in micro-electronic assembly and manufacturing techniques to provide the reliability and dependability required for industrial service. The totalizer operates from an internal lithium battery. Battery life is up to 10 years.

## PANEL MOUNT

Totalizers should be mounted in a grounded panel.

1. After cutting an opening  $1 \frac{5}{16}'' \times 2 \frac{5}{8}''$  in the panel, slide the panel gasket over the rear of the totalizer body up to the back of the bezel.
2. Slide the totalizer through the panel cutout.
3. Install mounting clips on each side of the totalizer body with mounting screws.
4. Make sure that the side rails of the clips fit into the recesses in the side of the counter body so that the "tang ends" wedge between the panel opening and body as the screws are tightened.

## SPECIFICATIONS

<b>ACCURACY</b>	Plus or minus 2% of actual flow within the range specified for each meter size
<b>TEMPERATURE RANGE</b>	32° F minimum to 122°F maximum
<b>HUMIDITY</b>	5-95% RH, non-condensing @ 32°-122° F
<b>POWER SUPPLY</b>	3.0 VDC from internal lithium battery which will provide up to 10 years of continuous operation. Count and reset contacts which remain closed for long periods of time will reduce battery life.
<b>INPUT SIGNAL</b>	Supplied by Model TR04-2, TR12-2, TR28-2 or TR29-2 transmitters. Maximum pulse transmission distance: 1,000 ft. (16 ohms max.)
<b>SHIPPING WEIGHT</b>	2 pounds
<b>ORDERING INFO</b>	Must be specified by the customer and includes: Complete description and specification of equipment to be used in conjunction with this instrument to assure system compatibility, Totalizer units.

## PANEL MOUNT

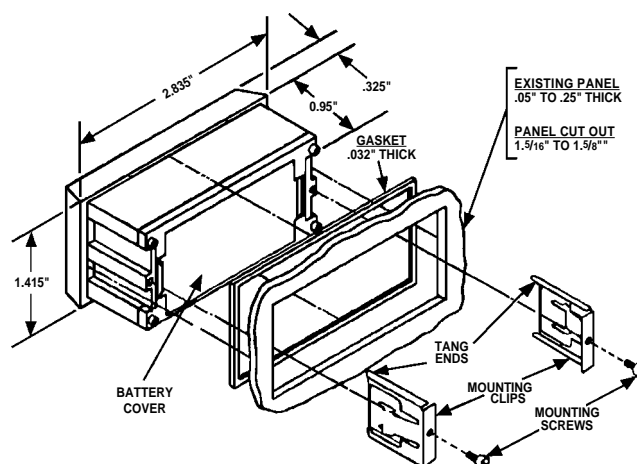

## MODEL IN16 REMOTE TOTALIZER SOLID STATE CONSTRUCTION CONTACT COUNT - INTERNAL POWER SUPPLY

SELECTION OF THE DESIRED RESET OPTION IS EASILY DONE BY WIRING THE CONNECTOR TO THE DESIRED RESET OPTION.

**REMOVING TERMINAL:** Insert the blade of a small screwdriver into slot of connector body, and gently push in to disengage the locking pawl. Pull terminal out.

**INSERTING TERMINAL:** When inserting into connector body, make sure the locking pawl is toward the slot in the connector. Push the terminal in until the pawl snaps into the slot.

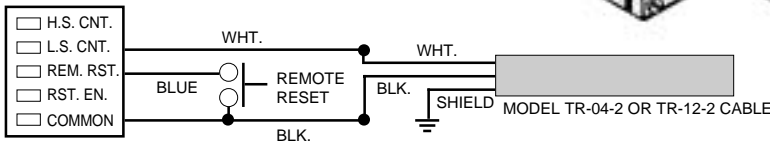
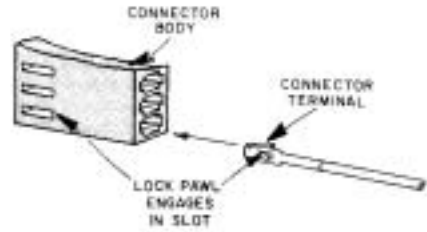
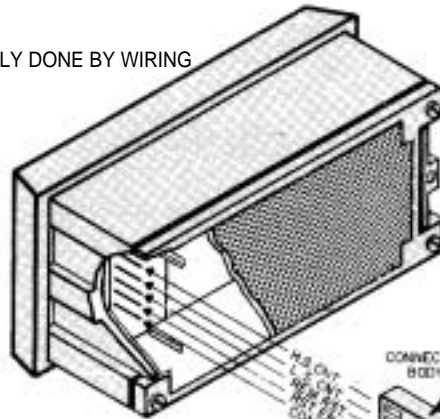

WIRING FOR REMOTE RESET ONLY

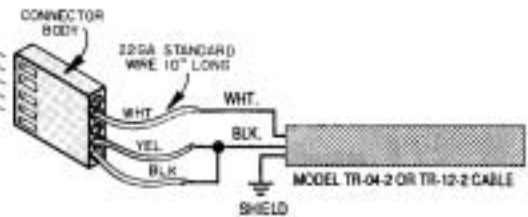

WIRING FOR PANEL RESET ONLY  
(AS SUPPLIED)

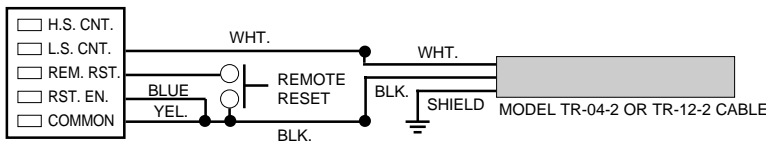

**NOTE:** WHEN NO RESET IS DESIRED, DISCONNECT THE YELLOW WIRE (USE THE BLACK AND WHITE WIRES ONLY).

### WIRING FOR REMOTE & PANEL RESET

1. Slide panel gasket (provided in accessory bag) over the back of the counter.
2. Attach two spring tab mounting clips to the side of the totalizer with two screws. (Clips and screws are provided in accessory bag)
3. Attach the base mount enclosure to panel or flat surface as application requires. Four bolts and nuts are provided with the base mount kit.
4. If hole in base mount is used, install grommet in hole and pull external signal wires from the TR04-2 or TR12-2 (and remote reset if used) into the enclosure through the grommet.
5. Cut wires from totalizer to a length of about 5" and make wire nut connections to incoming signal lines. (Wire nuts are provided)
6. Fold excess wire into rear of base mount while sliding the totalizer body into the enclosure until the spring tab mounting clips snap out to engage in the slots in the side of the base mount case.

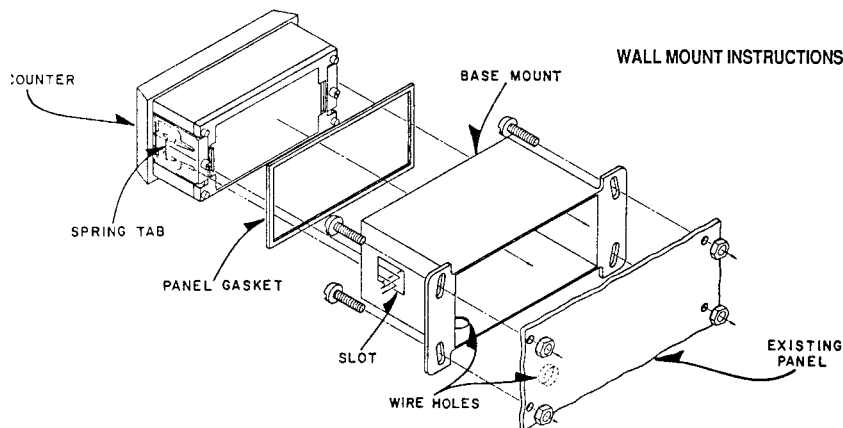

Visit our Website: [www.mccrometer.com](http://www.mccrometer.com)  
E-Mail: [info@mccrometer.com](mailto:info@mccrometer.com)

3255 WEST STETSON AVENUE • HEMET, CALIFORNIA 92545 USA  
TEL: 951-652-6811 • FAX: 951-652-3078

Copyright © 2004 McCrometer. All printed material should not be changed or altered without permission of McCrometer. The published technical data and instructions are subject to change without notice. Contact your McCrometer representative for current technical data and instructions.