

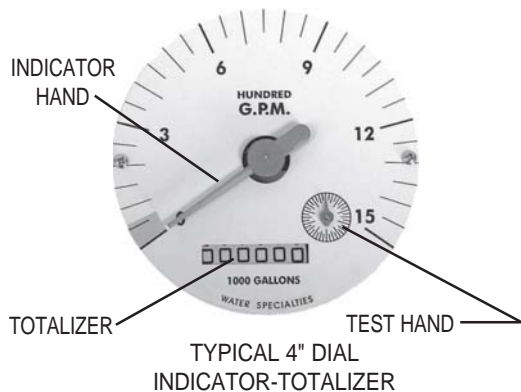

**MODEL VF32**  
 VERTICAL DOWNFLOW METER  
 SEALED METER MECHANISM - MAGNETIC DRIVE  
 INDICATOR - TOTALIZER  
 SIZES 4" thru 20"



#### DESCRIPTION

**MODEL VF32 VERTICAL DOWNFLOW METERS** are designed for mounting in tees with up to 150 PSI working pressure. The bolt-on design permits use in a wide range of applications with up to 150 psi working pressure. The mounting flange conforms to ANSI class 125 drilling. It is necessary, upon ordering, to furnish the I.D. dimension of the pipe the meter is to be mounted on for calibration purposes.

**INSTALLATION** is made by bolting the meter assembly to an appropriate cast iron or fabricated steel tee. These tees usually replace an elbow in existing systems such as on the suction or discharge side of a centrifugal pump or laterals in irrigation systems. The meter must have a full flow of liquid for proper accuracy. Fully opened gate valves, fittings or other obstructions that tend to set up flow disturbances should be a minimum of five pipe diameters upstream and two pipe diameters downstream from the meter.

**PROPELLER** is magnetically coupled with the drive mechanism through the sealed separator assembly. This completely eliminates water entering the meter assembly, as well as the need for any packing gland. The propeller is a conical shaped three bladed propeller, injection molded of thermoplastic material resistant to normal water corrosion and deformity due to high flow velocities.

**BEARING** in propeller is a water lubricated ceramic sleeve and spindle bearing system with a ceramic/stainless steel spindle. Dual ceramic thrust bearings, standard on all meters, handle flows in both forward and reverse directions. The bearing design promotes extended periods of maintenance free propeller operation. Bearings within the sealed meter mechanism are shielded precision stainless steel bearings and are factory lubricated for the life of the meter.

**INDICATOR-TOTALIZER** is mechanically driven by the meter mechanism and features a full 4" diameter, 250 degree sweep dial with a six digit, straight reading type totalizer and sweep test hand. The indicator drive mechanism is temperature compensated so the indicator will be accurate at all points on the dial when operated between 32° and 140° F. The indicator dial can be furnished in GPM, CFS, MGD or any standard liquid measuring units with choice of standard totalizer measuring units. The bonnet, with padlock hasp, is o-ring sealed to the meter head.

**CHANGE GEARS** may be easily exchanged in the field when changing the dial, or when recalibrating for different pipe sizes. It is not necessary to remove pressure from the line for these changes.

**O-RING SEALS** are used at all points where seals are required, making the meter mechanism completely immune to any of the corrosive effects of atmospheric moisture or the liquids measured by the meter assembly.

#### SPECIFICATIONS

|                           |   |
|---------------------------|---|
| <b>ACCURACY</b>           | Plus or minus 2% of actual flow within the range specified for each meter size.   |
| <b>PRESSURE RANGE</b>     | Up to 150 PSI maximum working pressure.   |
| <b>TEMPERATURE RANGE</b>  | 140° F Maximum. Consult factory for special construction for higher temperatures.   |
| <b>MINIMUM FLOWS</b>      | As shown for each meter size and construction are required for accurate registration. See flow chart. NOTE: Minimum flow will be higher when auxiliary equipment is added.  |
| <b>MAXIMUM FLOWS</b>      | As shown for each meter size and construction are rated for continuous operation. See flow chart.   |
| <b>INTERMITTENT FLOWS</b> | As shown for each meter size are rated for 10% to 15% of the total time the meter is operating. Consult factory for High Velocity construction when intermittent flows are higher than shown on flow chart and/or when longer operating periods are required.   |
| <b>MATERIALS</b>          | Used in construction are chosen to minimize the corrosive effects of the liquids measured by the meter assembly.<br>MAGNETS - permanent ceramic type<br>INTERIOR BEARINGS - shielded stainless steel<br>PROPELLER BEARING - ceramic sleeve type<br>PROPELLER SPINDLE - ceramic coated stainless steel<br>PROPELLER - injection molded thermoplastic<br>DROP-PIPE - stainless steel<br>SEPARATOR - stainless steel<br>SHAFTS AND BOLTS - stainless steel<br>METER HEAD - cast iron or fabricated steel, NSF approved, fusion epoxy coated. |
| <b>OPTIONAL EQUIPMENT</b> | A meter mounted Fwd. & Rev. Totalizer, Totalizer Extensions and a wide range of controls and instruments for indicating, totalizing and recording flow data for each meter. Special constructions and materials are available upon request.   |
| <b>ORDERING INFO</b>      | Must be specified by the customer and includes:<br>Minimum & maximum flow ranges<br>Temperature of meter environment<br>Indicator scale & units<br>Totalizer dial units<br>Type of materials and construction<br>Optional equipment desired<br>I.D. of pipe   |

**MODEL VF32**  
 VERTICAL DOWNFLOW METER  
 SEALED METER MECHANISM - MAGNETIC DRIVE  
 INDICATOR-TOTALIZER  
 SIZES 4" thru 20"

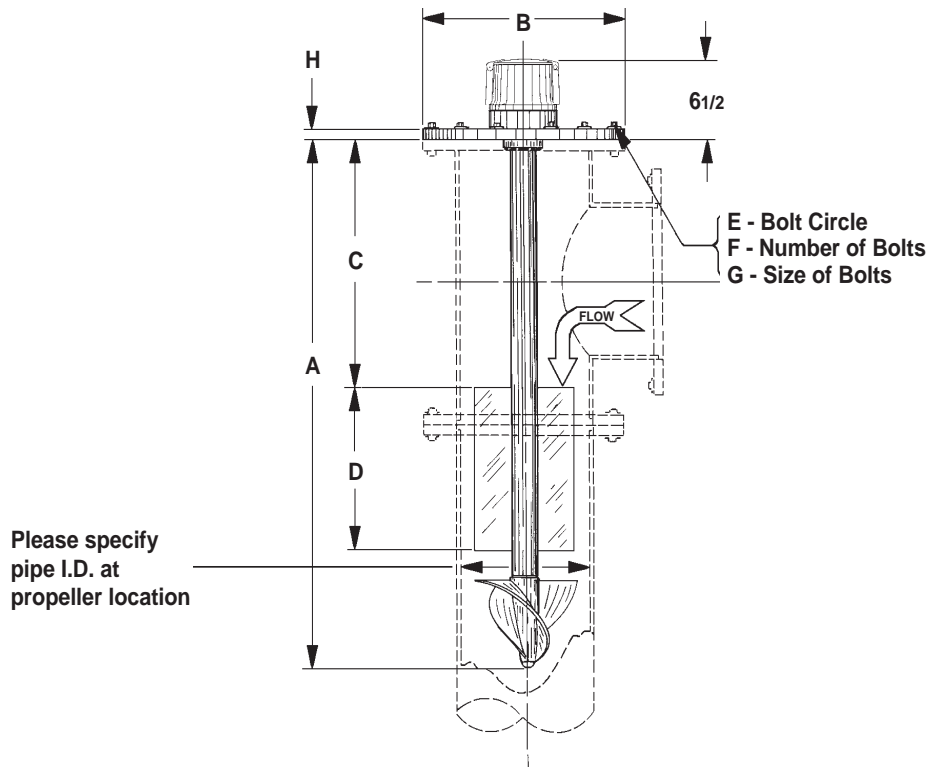

| METER & PIPE SIZE | FLOW RANGES, GPM |      |      | STANDARD DIAL FACE (GPM/GAL) | DIMENSIONS                     |                                |                                |    |                                |    |                               |                               | EST SHIPPING WEIGHT POUNDS |
|-------------------|------------------|------|------|------------------------------|--------------------------------|--------------------------------|--------------------------------|----|--------------------------------|----|-------------------------------|-------------------------------|----------------------------|
|                   | MIN.             | MAX. | INT. |                              | A                              | B                              | C                              | D  | E                              | F  | G                             | H                             |                            |
| 4                 | 55               | 500  | 700  | 500/100                      | 34                             | 9                              | 13 <sup>3</sup> / <sub>8</sub> | 12 | 7 <sup>1</sup> / <sub>2</sub>  | 8  | 5/8                           | 5/8                           | 70                         |
| 6                 | 130              | 1200 | 1500 | 1200/1000                    | 36 <sup>1</sup> / <sub>2</sub> | 11                             | 16                             | 12 | 9 <sup>1</sup> / <sub>2</sub>  | 8  | 3/4                           | 11/16                         | 90                         |
| 8                 | 170              | 1500 | 2000 | 1500/1000                    | 40 <sup>1</sup> / <sub>2</sub> | 13 <sup>1</sup> / <sub>2</sub> | 20                             | 12 | 11 <sup>3</sup> / <sub>4</sub> | 8  | 3/4                           | 11/16                         | 120                        |
| 10                | 200              | 2000 | 3000 | 2000/1000                    | 44                             | 16                             | 23 <sup>1</sup> / <sub>2</sub> | 12 | 14 <sup>1</sup> / <sub>4</sub> | 12 | 7/8                           | 11/16                         | 135                        |
| 12                | 220              | 3000 | 3500 | 3000/1000                    | 48                             | 19                             | 27 <sup>1</sup> / <sub>2</sub> | 12 | 17                             | 12 | 7/8                           | 13/16                         | 215                        |
| 14                | 320              | 4000 | 4500 | 4000/1000                    | 54                             | 21                             | 31 <sup>1</sup> / <sub>2</sub> | 14 | 18 <sup>3</sup> / <sub>4</sub> | 12 | 1                             | 15/16                         | 250                        |
| 16                | 420              | 5000 | 6000 | 5000/1000                    | 60                             | 23 <sup>1</sup> / <sub>2</sub> | 35 <sup>1</sup> / <sub>2</sub> | 16 | 21 <sup>1</sup> / <sub>4</sub> | 16 | 1                             | 1                             | 280                        |
| 18                | 720              | 6000 | 7500 | 6000/1000                    | 66                             | 25                             | 39 <sup>1</sup> / <sub>2</sub> | 18 | 22 <sup>3</sup> / <sub>4</sub> | 16 | 1 <sup>1</sup> / <sub>8</sub> | 11/16                         | 310                        |
| 20                | 870              | 7000 | 9000 | 8000/10000                   | 72                             | 27 <sup>1</sup> / <sub>2</sub> | 43 <sup>1</sup> / <sub>2</sub> | 20 | 25                             | 20 | 1 <sup>1</sup> / <sub>8</sub> | 1 <sup>1</sup> / <sub>8</sub> | 390                        |



Visit our Website: [www.mccrometer.com](http://www.mccrometer.com)

3255 WEST STETSON AVENUE • HEMET, CALIFORNIA 92545 USA  
 TEL: 951-652-6811 • FAX: 951-652-3078

Copyright © 2006 McCrometer. All printed material should not be changed or altered without permission of McCrometer. The published technical data and instructions are subject to change without notice. Contact your McCrometer representative for current technical data and instructions.