

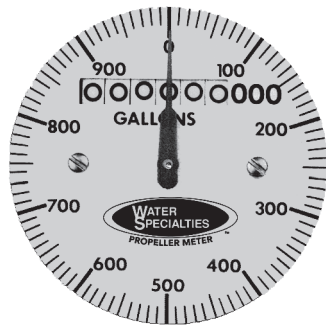

MODEL LP03
 150 psi FLANGED TUBE METER
 SEALED METER MECHANISM - MAGNETIC DRIVE
 STRAP-ON SADDLE - SEALED TOTALIZER
 SIZES 4" thru 16"

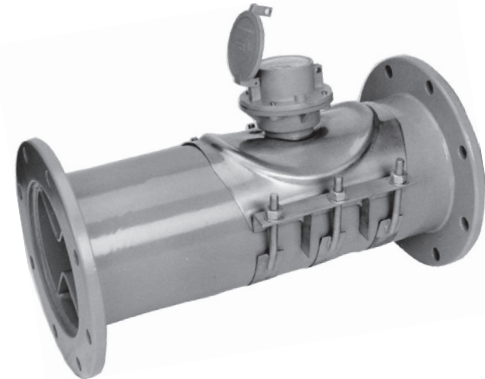

TOTALIZER



DESCRIPTION

MODEL LP03 FLANGED TUBE METERS are designed for irrigation or other low pressure service up to 150 PSI working pressure. The meter assembly features a strap-on saddle that attaches to the tube by means of u-bolts or u-straps furnished with the meter. Flanged ends are 150 lb. AWWA class D flat face steel flanges. Fabricated steel meter tubes have straightening vanes and are protected internally and externally with 12-15 mils of fusion epoxy resin.

INSTALLATION is made similar to placing a short length of flanged end pipe in the line. The meter can be installed in any of the following positions: vertically, horizontally, or inclined on suction or discharge lines. The meter must have a full flow of liquid for proper accuracy. Fully opened gate valves, fittings, or other obstructions that tend to set up flow disturbances should be a minimum of five pipe diameters upstream and one pipe diameter downstream from the meter.

PROPELLER is magnetically coupled with the drive mechanism through the sealed oil filled gearbox. This completely eliminates water entering the meter assembly, as well as the need for any packing gland. The propeller is a conical shaped three bladed propeller, injection molded of thermoplastic material resistant to normal water corrosion and deformity due to high flow velocities.

BEARING in propeller is a water lubricated ceramic sleeve and spindle bearing system with a ceramic/stainless steel spindle. Dual ceramic thrust bearings, standard on all meters, handle flows in both forward and reverse directions. The bearing design promotes extended periods of maintenance free propeller operation.

TOTALIZER is o-ring sealed and magnetically coupled with the driving mechanism, and features a six digit totalizer with a full 3" diameter, 100 division, center sweep dial that permits extremely accurate readings for timing purposes in determining flow rates. The totalizer dial can be furnished in gallons, cubic feet, acre feet, or any standard liquid measuring units. The bonnet, with padlock hasp, can be positioned in four different directions for the easiest possible reading when the meters are mounted in unusual positions.

CHANGE GEARS may be easily exchanged in the field when changing the dial, or when recalibrating for different pipe sizes. It is not necessary to remove pressure from the line for these changes.

O-RING SEALS are used at the meter head and all points where seals are required, making the meter mechanism completely immune to any of the corrosive effects of atmospheric moisture or the liquids measured by the meter assembly.

SPECIFICATIONS

ACCURACY	Plus or minus 2% of actual flow within the range specified for each meter size.
PRESSURE RANGE	Up to 150 PSI maximum working pressure.
TEMPERATURE RANGE	140° F Maximum. Consult factory for special construction for higher temperatures.
MINIMUM FLOWS	As shown for each meter size and construction are required for accurate registration. See flow chart. NOTE: Minimum flow will be higher when auxiliary equipment is added.
MAXIMUM FLOWS	As shown for each meter size and construction are rated for continuous operation. See flow chart.
INTERMITTENT FLOWS	As shown for each meter size are rated for 10% to 15% of the total time the meter is operating. Consult factory for High Velocity construction when intermittent flows are higher than shown on flow chart and/or when longer operating periods are required.
MATERIALS	Used in construction are chosen to minimize the corrosive effects of the liquids measured by the meter assembly. MAGNETS - permanent ceramic type VERTICAL SHAFT BEARING - shielded stainless steel PROPELLER BEARING - ceramic sleeve type PROPELLER SPINDLE - ceramic sleeve/stainless steel PROPELLER - injection molded thermoplastic GEARBOX - cast bronze SEPARATOR, SHAFTS and BOLTS - stainless steel SADDLE - fusion epoxy coated ductile iron (4") or stainless steel (6" - 16") LUG STRIPS - stainless steel (6" - 16") U-BOLTS - (4") electro-galvanized dichromate sealed 101 B steel U-STRAPS - stainless steel (6" - 16") METER TUBE - fabricated steel with straightening vanes and coated inside and out with 12-15 mils of fusion epoxy by the fluidized bed method.
OPTIONAL EQUIPMENT	Totalizer extensions and a wide range of controls and instruments for indicating, totalizing and recording flow data for each meter. Special constructions and materials are available upon request.
ORDERING INFO	Must be specified by the customer and includes: Minimum and maximum flow ranges Temperature of meter environment Totalizer dial units Type of materials and construction Optional equipment desired

MODEL LP03
 150 psi FLANGED TUBE METER
 SEALED METER MECHANISM - MAGNETIC DRIVE
 STRAP-ON SADDLE - SEALED TOTALIZER
 SIZES 4" thru 16"

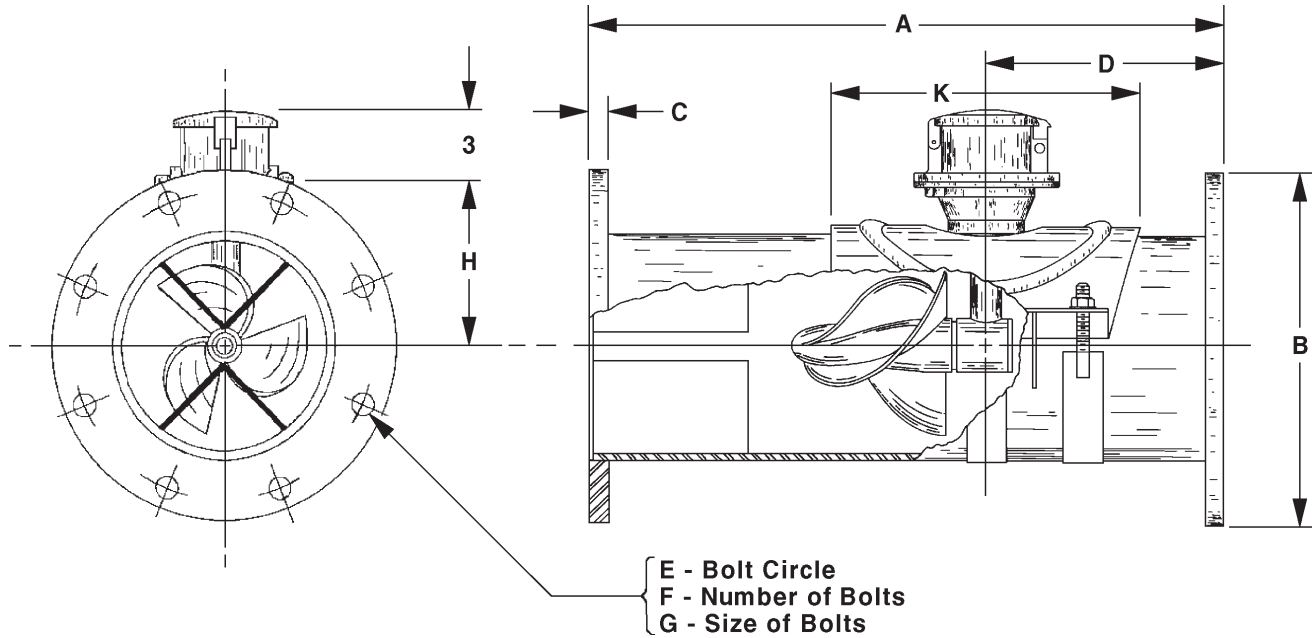

METER & PIPE SIZE	FLOW RANGES, GPM			DIMENSIONS									EST SHIPPING WEIGHT POUNDS
	MIN.	MAX.	INT.	A	B	C	D	E	F	G	H	K	
4	80	500	700	18	9	5/8	7	7½	8	5/8	5 ³ / ₁₆	10	122
6	200	1200	1500	22	11	11/16	9	9½	8	3/4	5¼	12	141
8	250	1500	2000	24	13½	11/16	9	11¼	8	3/4	6¼	12	161
10	300	2000	3000	26	16	11/16	10	14¼	12	7/8	7 ³ / ₈	12	195
12	350	3000	3500	28	19	13/16	10	17	12	7/8	8 ³ / ₈	12	225
14	450	4000	4500	42	21	15/16	12	18¾	12	1	9	12	300
16	500	5000	6000	48	23½	1	12	21¼	16	1	10	12	350