

MODEL ML100

DESCRIPTION

Model ML100 Irrigation Flowmeters are designed to provide accurate flow measurement at moderate pressure ratings in an inexpensive package. The impeller and drive assembly are removed and replaced through the open end of the meter tube. As with all McCrometer propeller flowmeters, standard features include magnetically coupled drive, instantaneous flowrate indicator and straight-reading, six-digit totalizer.

Impellers are manufactured of high-impact plastic, capable of retaining their shape and accuracy over the life of the meter. Each impeller is individually calibrated at the factory to accommodate the use of any standard McCrometer register. The ML100 can be field-serviced without the need for factory recalibration. Factory lubricated, stainless steel bearings are used to support the impeller shaft. The sealed bearing design limits the entry of materials and fluids into the bearing chamber providing maximum bearing protection.

The instantaneous flowrate indicator is standard and available in gallons per minute, cubic feet per second, liters per second and other units. The register is driven by a flexible steel cable encased within a protective vinyl liner. The register housing protects both the register and cable drive system from moisture while allowing clear reading of the flowrate indicator and totalizer.

INSTALLATION

Standard installation is horizontal mount. If the meter is to be mounted in the vertical position, please advise the factory. A straight run of full pipe the length of ten pipe diameters ahead and two diameters behind the meter is the minimum normally recommended for meters without straightening vanes. Meters with straightening vanes require at least five pipe diameters ahead and two diameters behind the meter.



The McCrometer Propeller flowmeter comes with a standard instantaneous flowrate indicator and straight-reading totalizer. An optional FlowCom register is also available. Typical face plates.

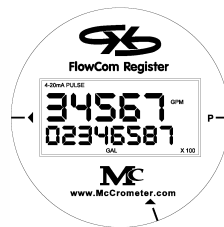

APPLICATIONS

The McCrometer propeller is the most widely used flowmeter for agricultural and turf irrigation measurement. Typical applications include:

- Center pivot systems
- Sprinkler irrigation systems
- Golf course and park water management
- Drip irrigation systems
- Gravity turnouts from underground pipelines
- Commercial nurseries

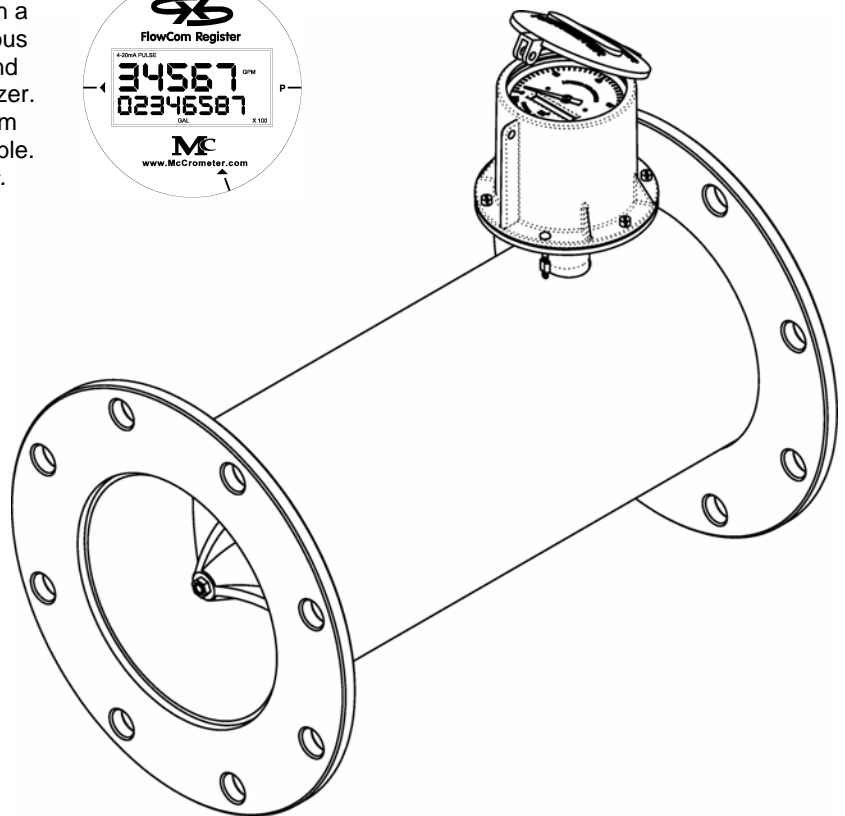

LOW COST IRRIGATION FLOWMETER MODEL ML100

SPECIFICATIONS

PERFORMANCE

ACCURACY/REPEATABILITY: ±2% of reading guaranteed throughout full range. ±1% over reduced range. Repeatability 0.25% or better

RANGE: See dimensions chart below

HEAD LOSS: See dimensions chart below

MAXIMUM TEMPERATURE: (Standard Construction) 160°F constant.

PRESSURE RATING: 75 psi

MATERIALS

TUBE: Epoxy-coated carbon steel pipe, conforming to ASA pipe standards. Lightweight irrigation flanges with 150 pound drilling

BEARING ASSEMBLY: Impeller shaft is 316 stainless steel. Ball bearings are 440C stainless steel.

MAGNETS: (Permenant type) Cast or sintered Alnico

BEARING HOUSING: Brass; Stainless Steel optional

REGISTER: An instantaneous flowrate indicator and six-digit straight-reading totalizer are standard. The

register is hermetically sealed within a die cast aluminum case. This protective housing includes a domed acrylic lens and hinged lens cover with locking hasp.

IMPELLER: Impellers are manufactured of high-impact plastic, retaining their shape and accuracy over the life of the meter. High temperature impeller is optional.

COATING: Fusion-bonded epoxy.

OPTIONS

- Forward/reverse flow measurement
- Register extensions
- Flow straightening vanes
- "Over Run" bearing assembly for higher than normal flowrates
- Electronic propeller meter available in all sizes of this model
- A complete line of flow recording/control instrumentation
- Certified calibration test results
- Stainless steel bearing housing

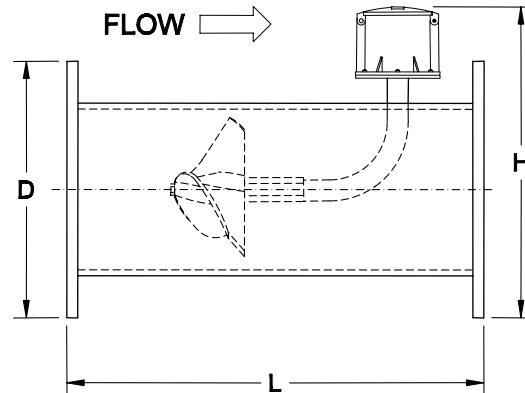
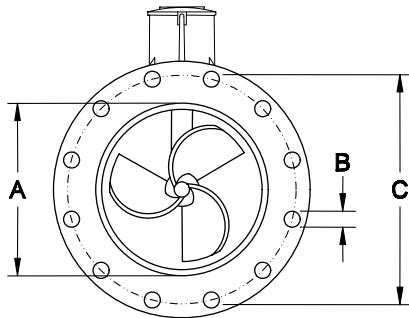

McCrometer reserves the right to change design or specifications without notice.

ML100	DIMENSIONS			
Meter Size	6"	8"	10"	12"
Maximum Flow U.S. GPM	1200	1500	1800	2500
Minimum Flow. U.S. GPM	90	100	125	150
Approx. Head Loss in Inches at Max. Flow	17.00	6.75	3.75	2.75
Approx. Shipping Weight, lbs.	50	61	104	125
A (inches)	6	8	10	12
B (inches)	7/8	7/8	1	1
C (inches)	9 1/2	11 3/4	14 1/4	17
D (inches)	11	13 1/2	16	19
H (inches)	16 1/4	18 1/2	21 3/4	24 1/4
L (inches)	20	20	20	20
No. of Bolts Per Flange	8	8	12	12

FOR MORE INFORMATION CONTACT:



3255 West Stetson Avenue
Hemet CA 92545 USA
951-652-6811 / FAX 951-652-3078
www.mccrometer.com