



**MODEL 282L  
ONE INCH FULL PIPE  
SENSOR**

**INSTALLATION AND PROFILING  
MANUAL**

**JULY 2010**

*PATENT NOTICE*

This equipment is manufactured under  
one or more of the following U.S. Patents:  
4083246; 4549434; 4459858



**3255 WEST STETSON AVENUE  
HEMET, CALIFORNIA 92545 U.S.A.**

**PHONE: 951-652-6811  
FAX: 951-652-3078  
VISIT OUR WEBSITE: [www.mccrometer.com](http://www.mccrometer.com)**



## ABOUT THIS MANUAL

The purpose of this manual is to provide the information necessary to install the one inch full pipe sensor and profile the flow. Along with this manual you will need an installation and operations manual for the flowmeter.

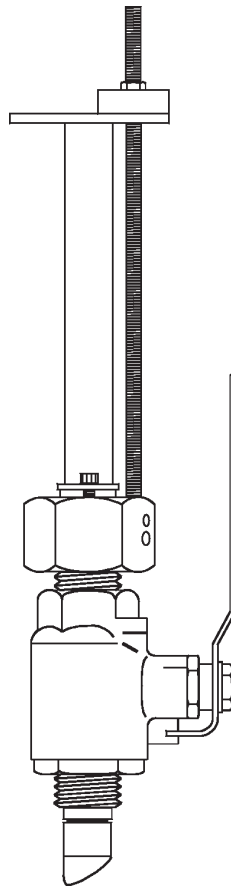

**ONE INCH FULL  
PIPE SENSOR AND  
INSERTION HARDWARE**

# Table of Contents

<b>SAFETY SUMMARY</b> .....	v
Never Enter a Confined Space Without Testing the Air.....	v
Never Enter a Confined Space Without the Proper Safety Equipment .....	v
Never Enter a Confined Space Without Standby/Rescue Personnel.....	v
<b>SENSOR HANDLING</b> .....	vi
<b>SPECIFICATIONS</b> .....	vii
Velocity Measurement .....	vii
Materials .....	vii
Pressure/Temperature Limits .....	vii
Dimensions .....	vii
<b>SECTION I: GENERAL DESCRIPTION</b> .....	1-1
Sensor.....	1-1
Insertion Hardware.....	1-1
Flow Measurement.....	1-2
Velocity Profile .....	1-2
Mean Velocity .....	1-2
Sensed Velocity .....	1-2
Flow Calculation.....	1-2
Velocity Multipliers (K1, K2, K3) .....	1-3
Calculating the Velocity Multipliers .....	1-3
Calculating the Mean Velocity .....	1-3
Isotachs .....	1-4
Sensor Location .....	1-4
<b>SECTION II: APPLICATION SCHEMATICS</b> .....	2-1
Clearance.....	2-1
Skewed Profiles.....	2-1
90° Elbow.....	2-2
T - Junction .....	2-3
Y - Junction.....	2-4
Active Valves.....	2-5
Small Large Pipe Junction .....	2-6

<b>SECTION III: INSTALLATION AND PROFILING</b> .....	3-1
Flowmeter .....	3-1
Sensor .....	3-1
Location, Position, and Clearance .....	3-1
Access Hole .....	3-1
Check Sensor Alignment.....	3-2
Measure Length C.....	3-3
Install the Compression Seal.....	3-3
Check Pipe ID.....	3-4
Measuring the Velocity Profile.....	3-5
Far Wall Method .....	3-5
Sensor Location Check .....	3-7
Mean Velocity ( $\bar{U}$ ) Calculation .....	3-7
Velocity Multiplier (K1, K2, K3).....	3-8
Sensor Operating Position (Raw Waste Water).....	3-8
Sensor Operating Position (Clean Water) .....	3-8
Measuring the Velocity Profile.....	3-9
Near Wall Method .....	3-9
Sensor Location Check .....	3-11
Mean Velocity ( $\bar{U}$ ) Calculation .....	3-11
Sensor Operating Position.....	3-12
1/8 D Profile .....	3-12
1/8 D Sensor Position.....	3-12
Options.....	3-14
Cable Disconnect Option .....	3-14
Pressure Options .....	3-15
One Inch Full Pipe Sensor Parts Illustration.....	3-16
<b>SECTION IV: PARTIAL PROFILES</b> .....	4-1
Partial Profiling Methods .....	4-1
Profile Curve Estimation.....	4-2
Far/Near Wall Sensor Location Velocities .....	4-3
Complete the Profile Curve.....	4-3
<b>PROFILING DATA LOGS</b> .....	4-4

# SAFETY SUMMARY

The following are general safety precautions that are not related to any specific procedure and therefore do not appear elsewhere in this publication. These are the recommended precautions that personnel must understand and apply when working in confined spaces. Examples of confined spaces are boilers, furnaces, degreasers, pipelines, pits, pumping stations, septic tanks, sewage digesters, man-holes, vaults, and storage tanks.

## **NEVER ENTER A CONFINED SPACE WITHOUT TESTING THE AIR**

The air inside confined spaces may be toxic, oxygen deficient, or explosive due to a lack of good ventilation. This is because most confined spaces are not designed for workers to enter and work on a routine basis.

Do not trust your senses to determine if the air in a confined space is safe. You cannot see or smell many of the toxic gases or vapors. Test the space at the bottom, middle, and top.

## **NEVER ENTER A CONFINED SPACE WITHOUT THE PROPER SAFETY EQUIPMENT**

Do not enter a confined space without the proper safety equipment such as a tripod, lifeline, and gas detector.

## **NEVER ENTER A CONFINED SPACE WITHOUT STANDBY/RESCUE PERSONNEL**

Only enter a confined space in the presence of someone who is capable of rendering aid. Standby personnel should not have any other duties but to serve as standby and know what action to take in case of an emergency. Standby personnel should not enter a confined space until help arrives and then only with proper equipment, life lines, and respirators.

### ***Comment:***

*Over 50% of workers who die in confined spaces are attempting to rescue other workers.*

## SENSOR HANDLING

To avoid damaging the sensor, observe the following rules when handling the insertion hardware:

- If the sensor is removed from the insertion tube, use twice the amount of Teflon tape on the sensor threads as you would normally use on pipe threads when it is put back on the insertion tube.
- In positioning the sensor at the far wall of the pipe, be careful. Do not jam the sensor into the far wall or force the captive nut when the sensor stops.
- Never force the sensor. If you feel any resistance or scraping, stop immediately and retract the sensor. Eliminate the source of the resistance before you try to reinsert the sensor.
- Make sure the corporation stop is completely open. A partially open corporation stop will scrape the side of the sensor and require sensor replacement.
- The top opening and bottom opening of corporation stops are not concentric. The result may be the sensor scraping the inside of the corporation stop. Consult the factory before you attempt to install the sensor into existing corporation stops.

Be very careful in handling the insertion tube when it is removed from the compression seal. A hard bump could break the sensor.

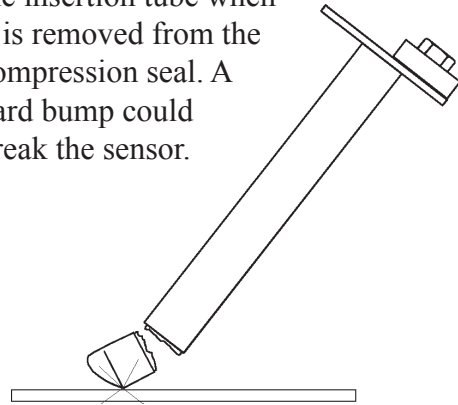

Correct: The insertion tube and restraining rod are parallel.

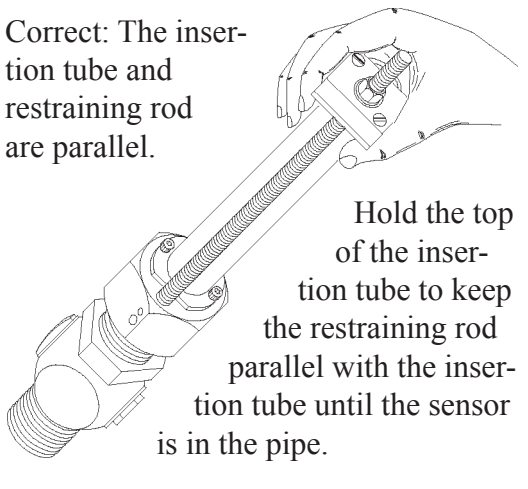

Incorrect: The insertion tube and restraining rod are not parallel.

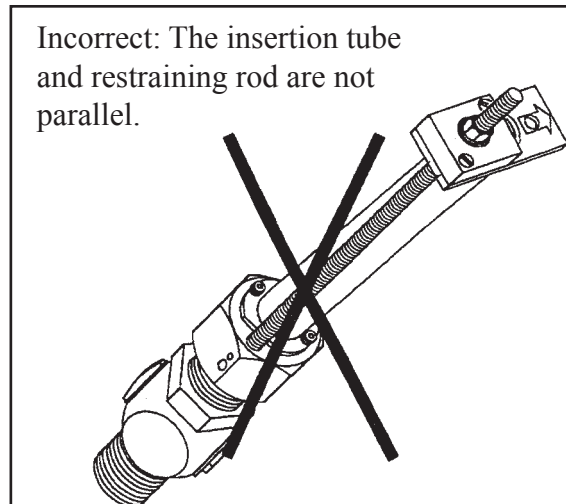

# SPECIFICATIONS

## VELOCITY MEASUREMENT

METHOD: Electromagnetic (Faraday's Law)

RANGE: -0.5 to +20 ft/sec (600 cm./sec)

ACCURACY:  $\pm 2\%$  of reading,  $\pm$  zero stability

ZERO STABILITY:  $\pm 0.03$  ft/sec

## MATERIALS

SENSOR: Polyurethane exposed to flow

SENSOR CABLE: Twinax Polyurethane outer jacket

SENSOR MOUNTING: 316 stainless steel exposed to flow

**PRESSURE / TEMPERATURE LIMITS** INSERTION TUBE: 250 psi @ 160° F

SENSOR: Flow temperature range 32° F to 160° F (0° C to 72° C) at 250 psi. Sensors for extreme environments are available, subject to application review - contact factory.

## DIMENSIONS

SENSOR: .937" Diameter (Requires 1" ball valve port clearance)

INSERTION HARDWARE: .937" Diameter, Lengths 12", 24", and 36"



# SECTION I

# GENERAL DESCRIPTION

## Sensor

The one inch full pipe sensor (Figure 1-1) measures water velocity in full pipes. The sensor operates on the Faraday principle which states that a conductor moving through a magnetic field produces a voltage that is directly proportional to the velocity of the conductor. An inductor inside the sensor produces the magnetic field, and two velocity electrodes on the surface of the sensor measure the voltage produced by the water (moving conductor). The flowmeter electronics convert the voltage measurement to a velocity output.

*Comment:*

*The purpose of the reference electrode is to suppress electrical noise that may be present in the water.*

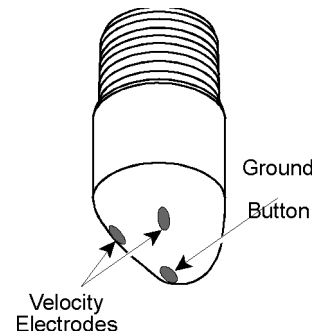

Figure 1-1. Sensor

## Insertion Hardware

The insertion hardware (Figure 1-2) consists of a sensor, sensor cable, ball valve, and insertion tube. The sensor is attached to the insertion tube and the insertion tube is inserted into the pipe through a 1" ball valve or corporation stop. A standard sensor cable is 20 feet long and terminates at a terminal strip or sensor disconnect.

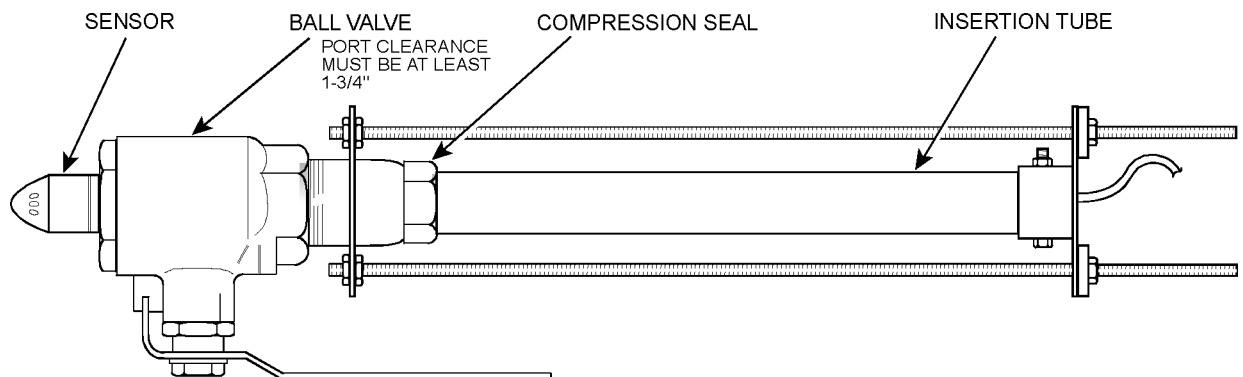

Figure 1-2. Insertion Hardware

# Flow Measurement

## Velocity Profile

The velocity profile is the velocity of the water at various positions on a plane across the pipe. These velocities vary and the slowest velocities are at or near the pipe wall. The result is a profile shape similar to the one shown in Figure 1-3. This shape is referred to as the theoretical profile.

*Comment:*

*Pipe elbows, valves or obstructions will cause the profile shape to change.*

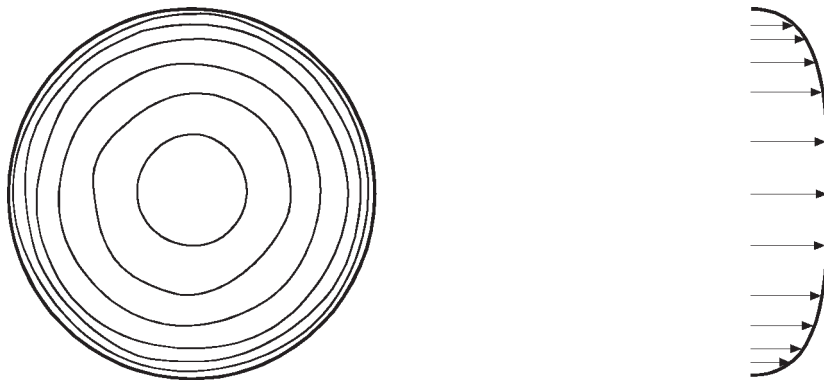

*Figure 1-3. Velocity Profile (Theoretical)*

## Mean Velocity

The mean velocity ( $\bar{U}$ ) is the average of all the velocities across the flow.

## Sensed Velocity

The sensed velocity ( $U$ ) is the velocity that is measured by the sensor which is located near the sensor electrodes.

## Flow Calculation

Flow is calculated with the continuity equation  $Q = \bar{U} \times A$  where  $Q$  is flow,  $\bar{U}$  is mean velocity and  $A$  is cross-sectional area of the pipe.

### Velocity Multipliers (K1, K2, K3)

The velocity multiplier (K) modifies the sensed velocity so that it can be used as the mean velocity in the continuity equation. One velocity multiplier (K1) is a first order multiplier and a first order multiplier assumes a linear relationship between the sensed velocity and the velocity profile. This may be significantly non-linear when:

- The difference between the minimum and maximum flow is three or more times.
- The sensor is located near an elbow, junction, or obstruction.

If the above conditions exist, a second or third order multiplier is appropriate. The third order equation is:

$$U = K_1 U_s + K_2 U_s^2 + K_3 U_s^3$$

Where (K) is the multiplier and ( $U_s$ ) is the sensed velocity.

### Calculating the Velocity Multipliers

We must have a sensed velocity and a mean velocity to calculate the velocity multiplier. Profiling is the method we use to get the mean velocity. When the flow is profiled, the velocity is measured at various locations across the flow.

*Comment:*

*A second order multiplier requires at least three profiles and a third order multiplier requires at least four profiles. The profiles should be evenly spaced over the range of flows and must include a profile of the minimum and maximum flow rates.*

*You will need the Flow Calculator software package to calculate second or third order multipliers. Factory assistance is also available.*

*Check the instruction manual for your model flowmeter to see if the meter can use second and third order multipliers.*

### Calculating the Mean Velocity

The pipe cross-section is divided into a number of concentric rings called annular areas (Figure 1-4). Although the velocity across the pipe changes, the velocity in a particular annular area is considered constant. Each annular area velocity is weighted because the amount of influence that each one has on the mean velocity calculation is different. To get the mean velocity, the weighted velocities are totaled then they are divided by a mean velocity factor.

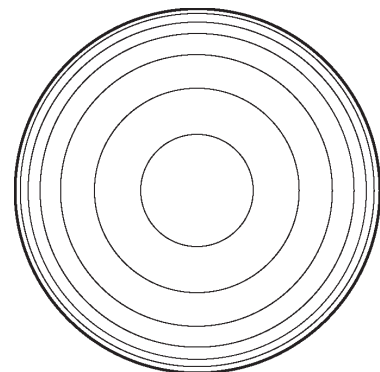

*Figure 1-4. Annular Areas*

The two inch profiling data log in the back of this manual has a column of sensor locations. Each location in this column represents an annular area. The velocity at each location is measured with the sensor and recorded in the log. The velocity at a particular location is multiplied by the weighting factor at that location. The weighted velocities are totaled and divided by the mean velocity factor at the bottom of the log to get the mean velocity.

### Isotachs

An isotach indicates a velocity gradient (Figure 1-5). This can be compared to a topographic map that shows the varying terrain with elevation lines. Notice that the isotachs in Figure 1-5 are concentric circles. These isotachs are from a fully developed profile in a straight run of pipe. This is the configuration that was used to develop the weighting factors in the profiling data log. The best results are attained in applications which have velocity profiles similar to the one used to develop the information in the profiling data log.

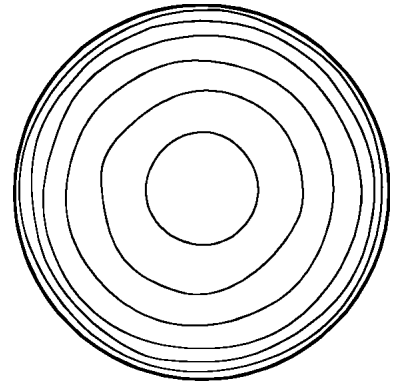

Figure 1-5. Isotachs

### Sensor Location

Locate the sensor as far as possible away from elbows, valves, and junctions. A few guidelines are as follows:

- The sensor should be located at least 5 pipe diameters upstream or 10 pipe diameters downstream from elbows and junctions.

*Comment:*

*The best results are obtained from a sensor that is as far as possible away from elbows, junctions, and obstructions.*

- The sensor must be located at least 10 pipe diameters upstream or 25 pipe diameters downstream from active valves.

## SECTION II

## APPLICATION SCHEMATICS

The application schematics (Pages 2-1 to 2-7) show different applications and the best sensor location for a particular application.

### Clearance

Distance H must be at least one insertion tube length plus 8

The sensor can be installed on vertical and horizontal pipes. However, on horizontal pipes, do not install the sensor at or near the top of the pipe. Air bubbles and grease float to the top and could affect readings.

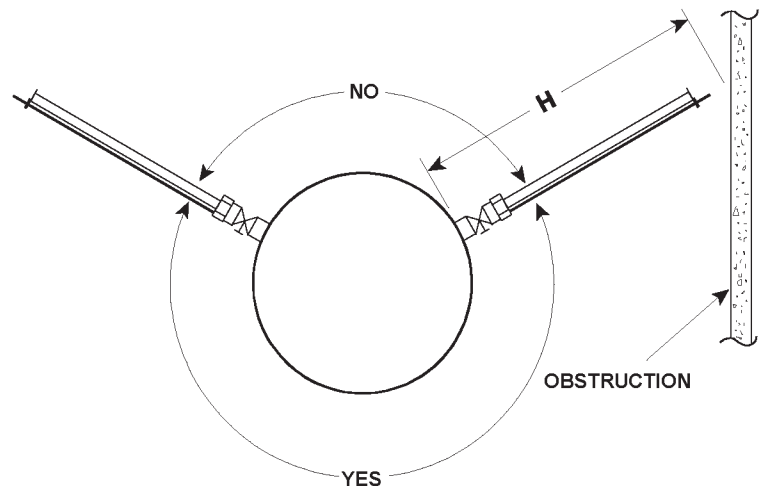

### Skewed Profiles

This profile is skewed too much to get good results. These locations are indicated by a NO in the application schematics.

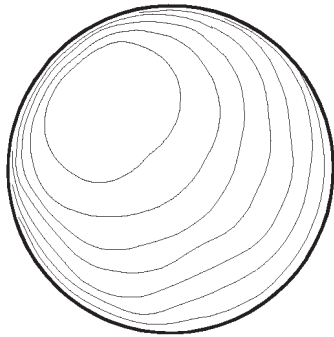

This profile is somewhat skewed. These locations, which are indicated by a NOT RECOMMENDED in the application schematics, should be avoided.

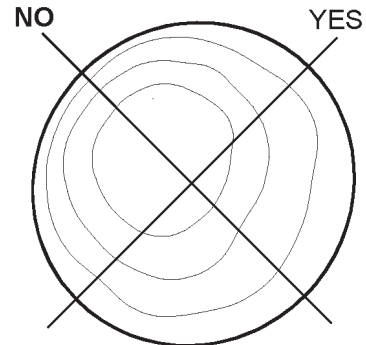

If a NOT RECOMMENDED location cannot be avoided, mount the sensor so that the profile is bisected asymmetrically when the pipe is traversed.

# 90° ELBOW

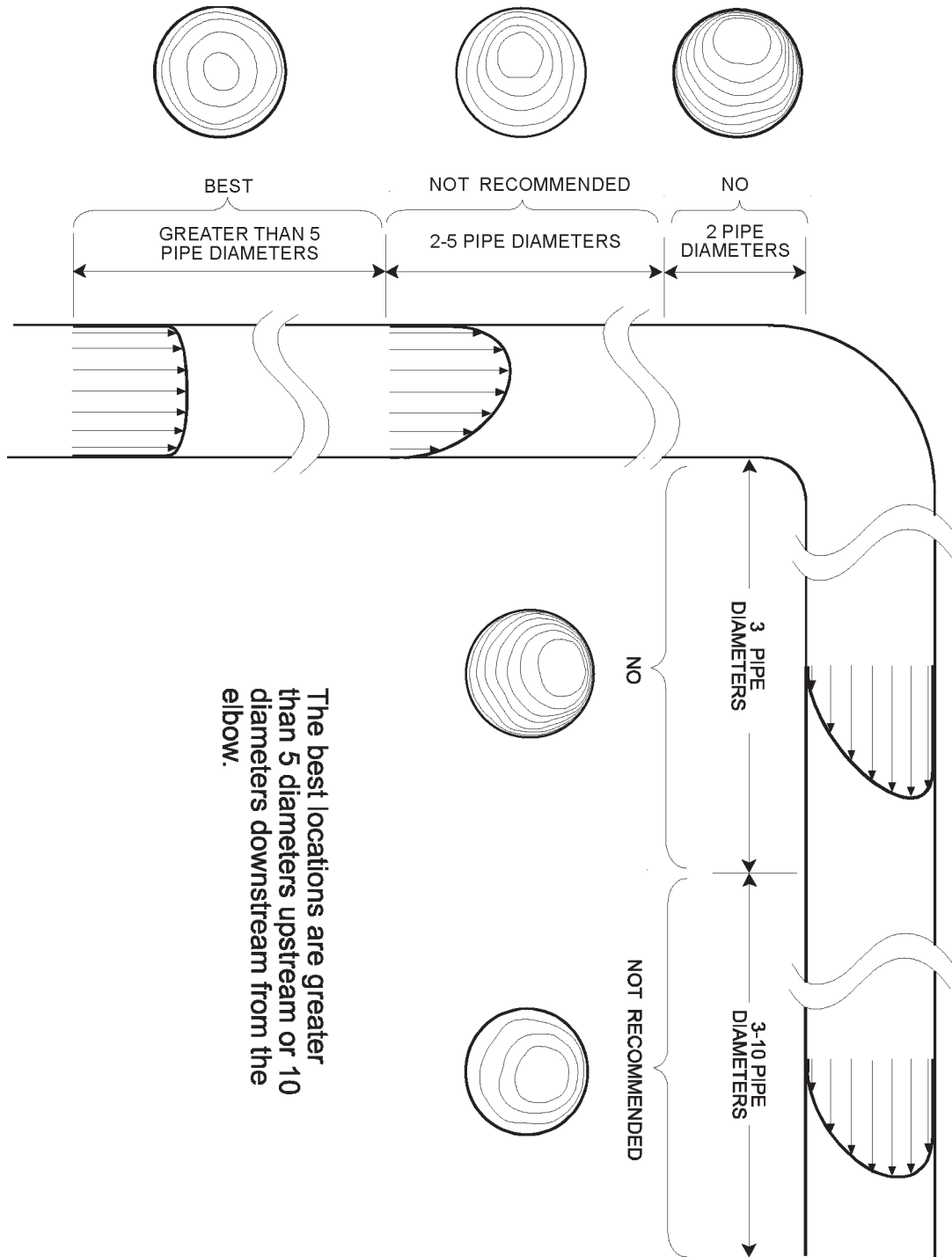

The best locations are greater than 5 diameters upstream or 10 diameters downstream from the elbow.

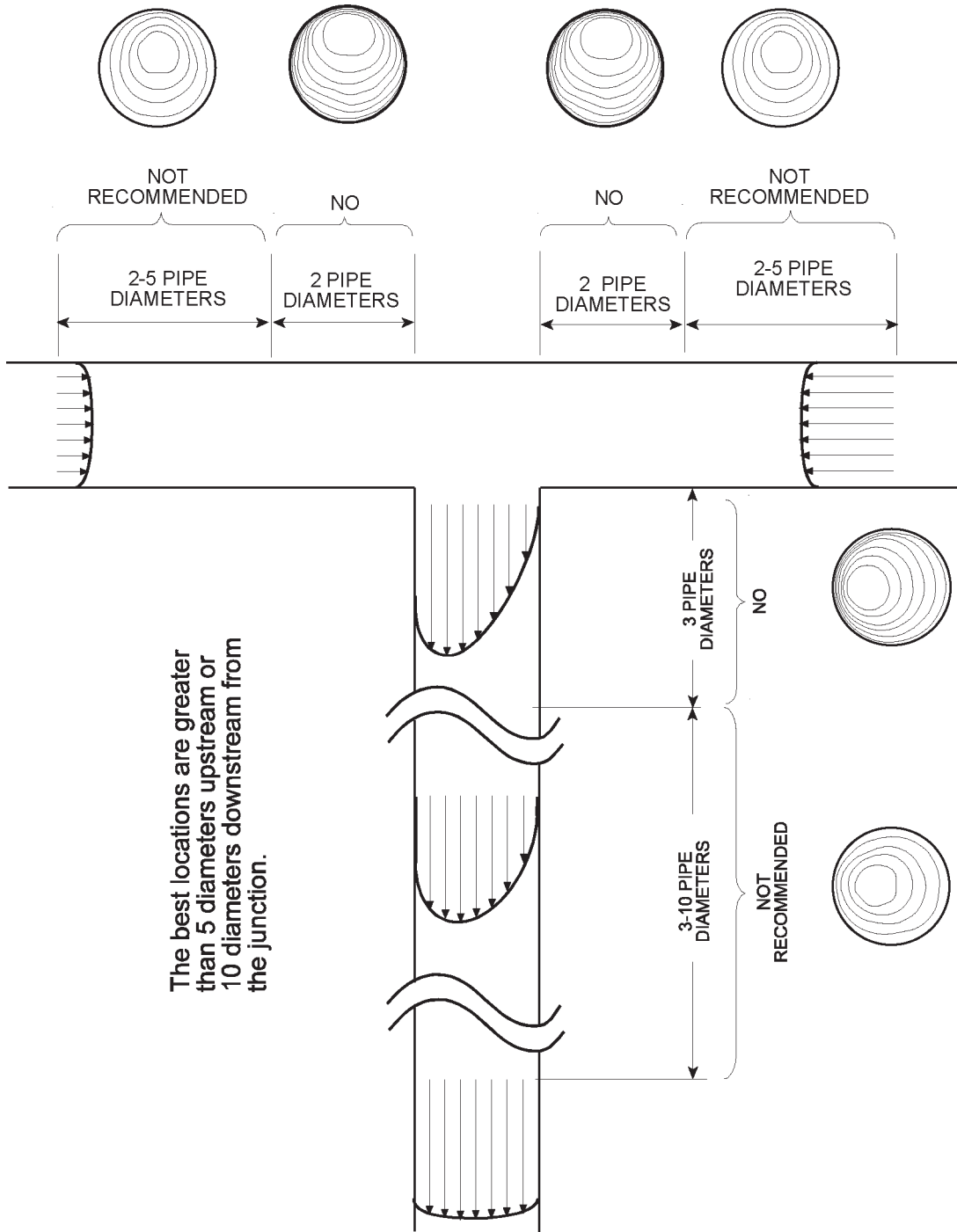

# T - JUNCTION

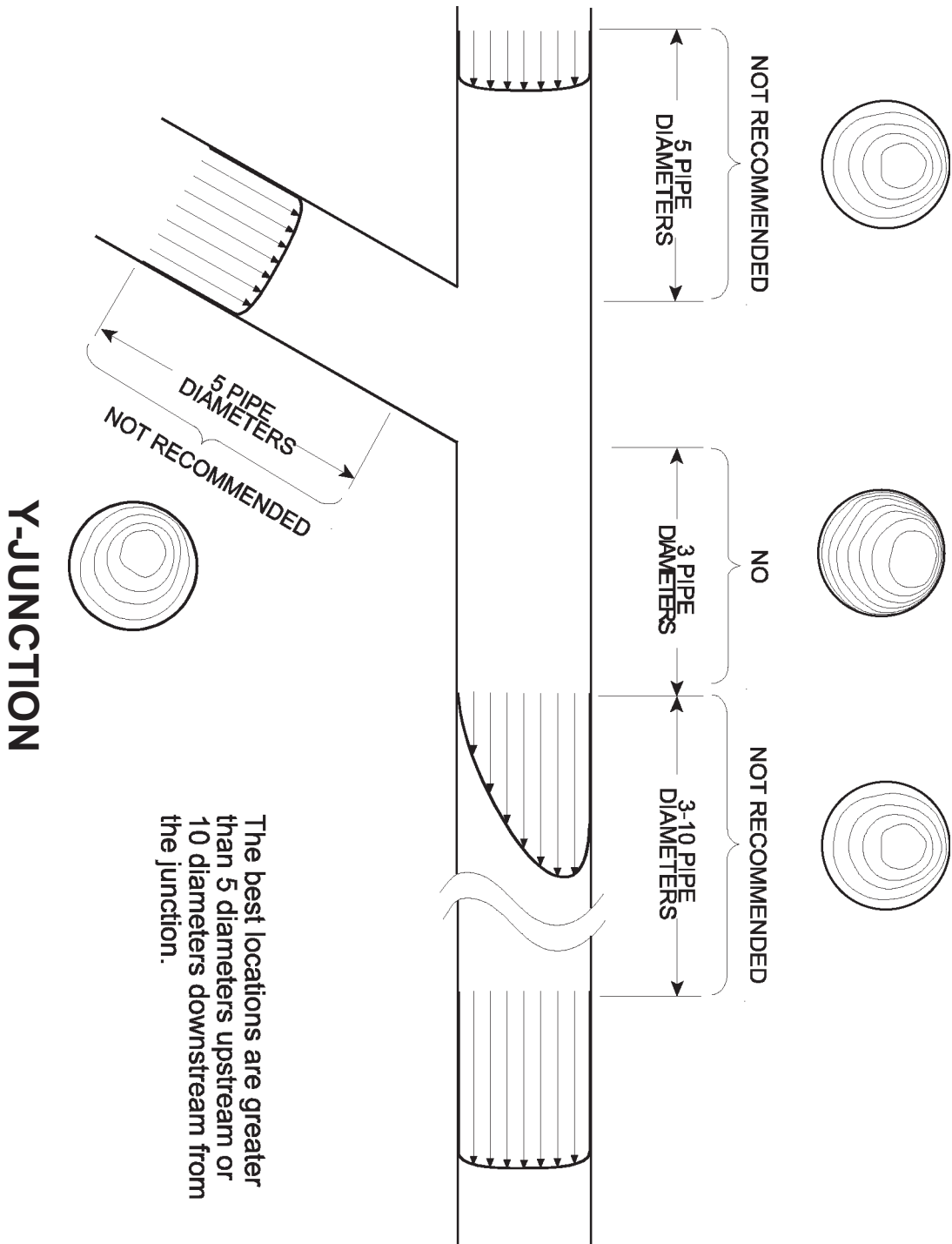



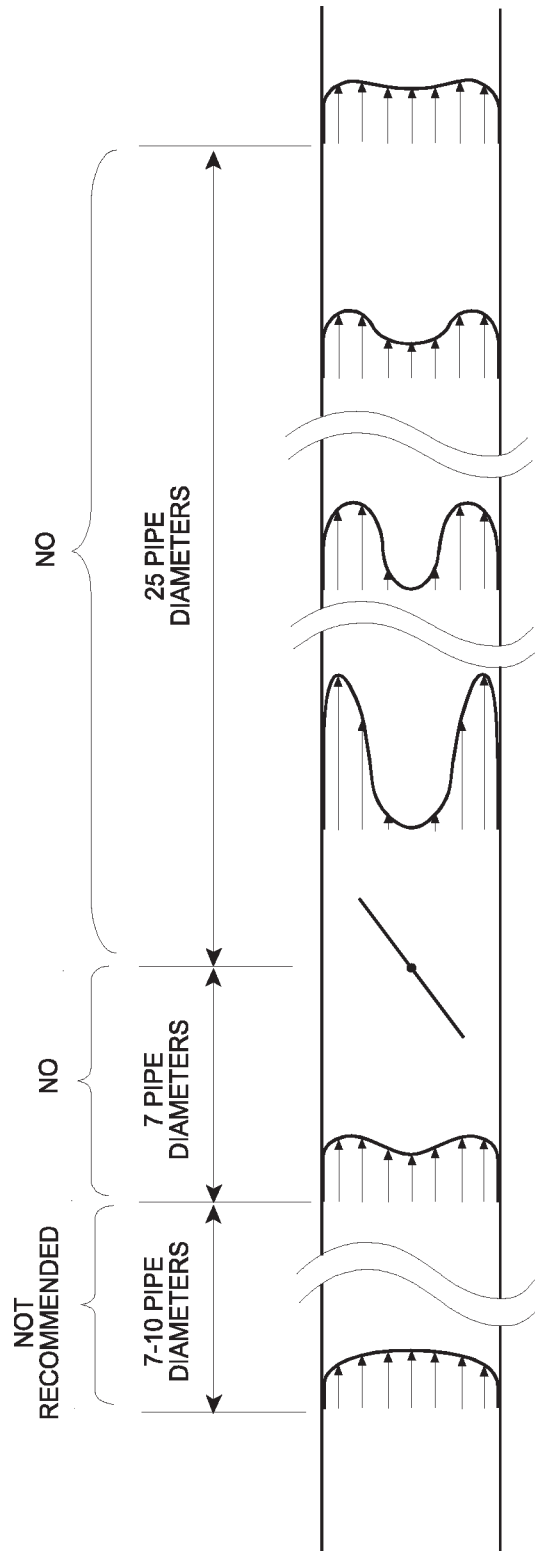

The purpose of an active valve is to vary the flow. An active valve will produce a distorted profile that changes as the flow changes. As a result, the sensor must be installed at least 10 diameters upstream or 25 diameters downstream from an active valve. The upstream side is the preferred location.

## ACTIVE VALVES

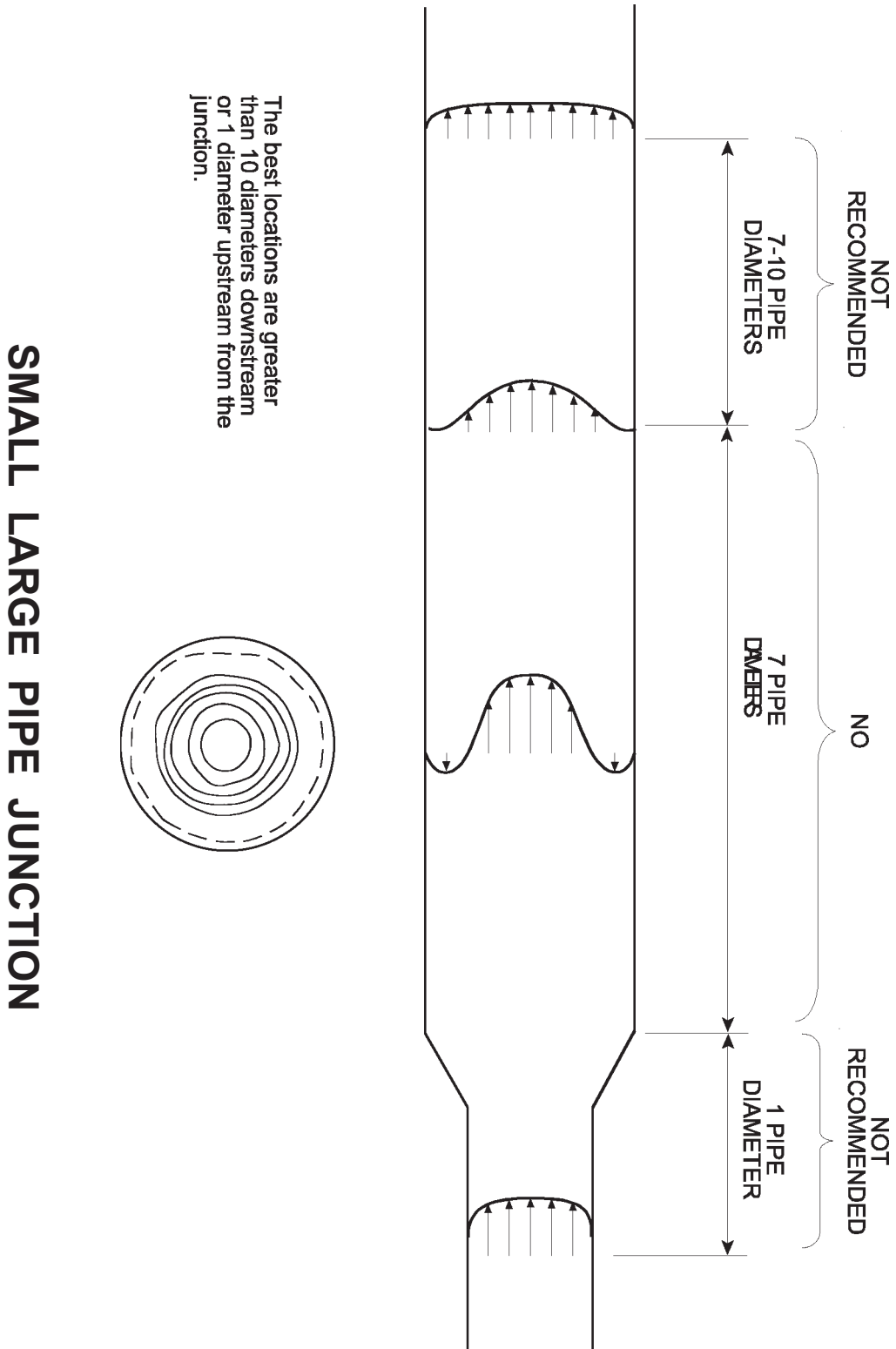

## SMALL LARGE PIPE JUNCTION

There may not be enough room in some pump stations to allow for the sensor to be installed 15 pipe diameters downstream from the last pump. If this is the case, the sensor will have to be installed in a manhole outside the pump station. Check with MMI for instruments that are best suited for pump station applications.

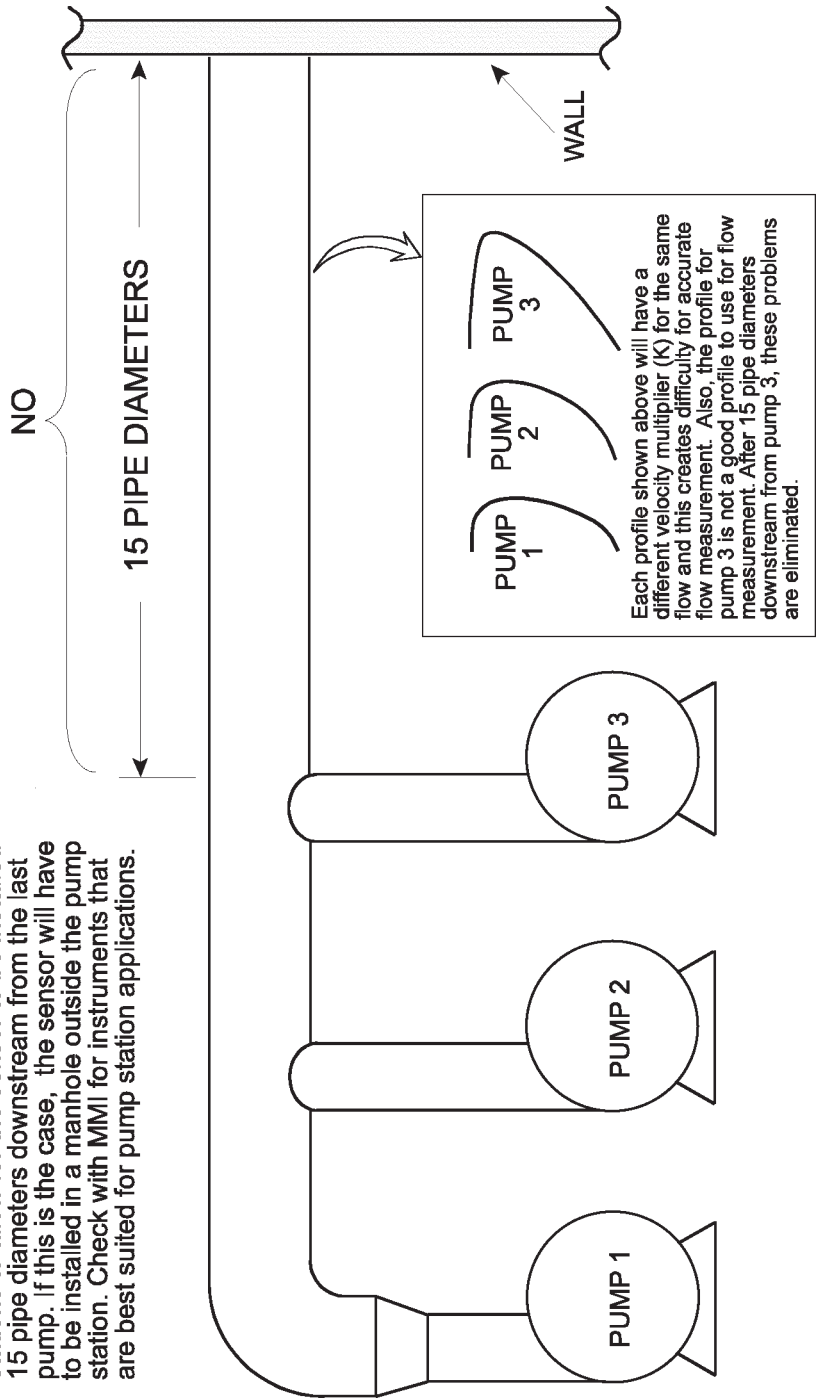

## PUMP STATION

## SECTION III                      INSTALLATION AND PROFILING

---

This instruction is for the installation of the sensor and insertion hardware. The sensor cable connections and flowmeter installation instructions are contained in the manual for your model flowmeter. The installation outline is as follows:

- Mount the flowmeter electronics.
- Install the sensor.
- Measure the inside diameter of the pipe.
- Profile the flow.
- Calculate Mean Velocity ( $\bar{U}$ ).
- Set the sensor at the operating position.
- Record the velocity at the operating position.
- Calculate the Velocity Multiplier.

### INSTALLATION

#### Flowmeter

Install the flowmeter as described in the technical manual for your model flowmeter.

#### Sensor

##### Location, Position, and Clearance

The Application Schematics (Pages 2-1 through 2-7) illustrate sensor location, position, and clearance requirements.

##### Access Hole

The pipe must be tapped and have a pipe nipple in place before the sensor can be installed. A smooth 1" access hole (Figure 3-1) and a flush pipe nipple (Figure 3-2) are required for accurate flow measurement in waste water applications. Clean water applications that can use the 1/8 D operating position do not have to have flush pipe nipples.

##### **WARNING**

*Tapping into pressurized pipes is dangerous and injury could result from improper tapping procedures.*

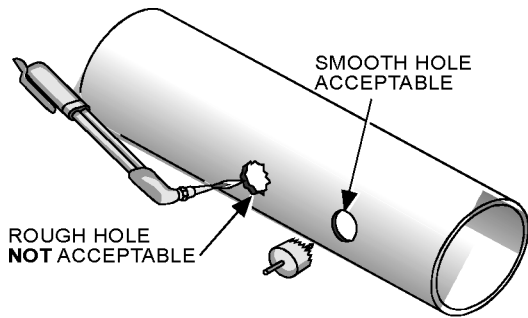

Figure 3-1. Access Hole

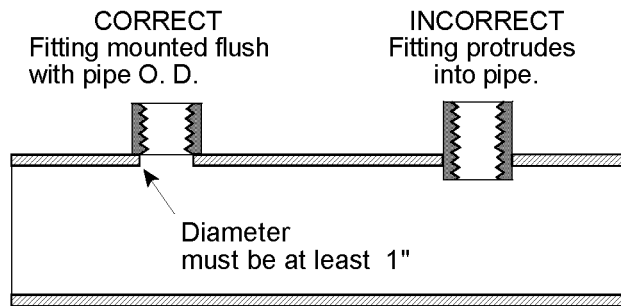

Figure 3-2. Pipe Nipple

### Check Sensor Alignment

The sensor, insertion tube, and compression seal are shipped as an assembled unit. To check sensor alignment:

- Remove the insertion tube and restraining rod from the compression seal.

*Comment:*

*Exercise care in handling the sensor and insertion tube (Sensor Handling Page i).*

*The sensor should not have to be removed from the insertion tube. If the sensor needs to be removed, call the factory.*

- Check sensor alignment (Figure 3-4). If the sensor needs to be aligned, use a strap wrench (Figure 3-3) to rotate the sensor. Do not force the sensor or use other types of wrenches.

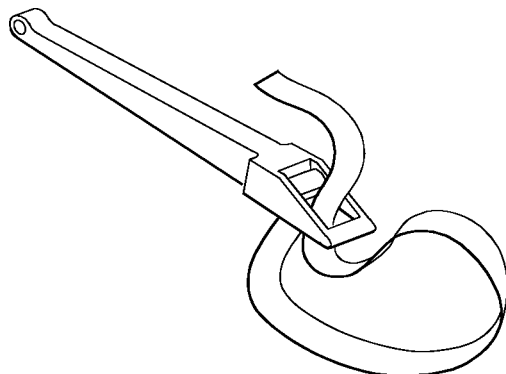

Figure 3-3. Strap Wrench

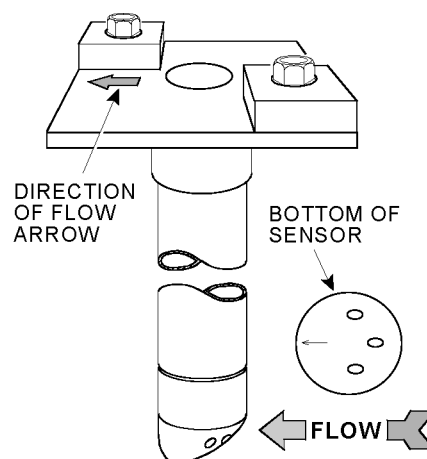

Figure 3-4. Sensor Alignment

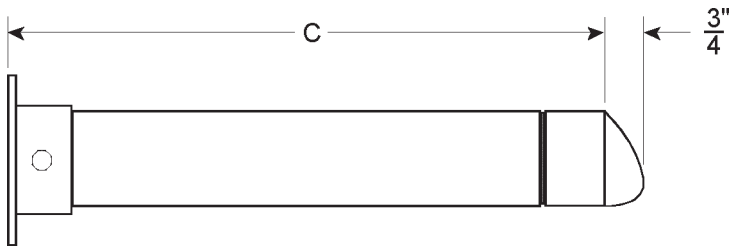

Figure 3-5. Length C

### Measure Length C

Measure and write down length C. This is measured from the top edge of the insertion tube cap to the start of the tapered section on the sensor (Figure 3-5). You will need this measurement to do the profile.

### Install the Compression Seal

Install the ball valve on the pipe nipple. Use teflon tape to seal the pipe threads. Do not use pipe dope because the unit will only output near zero velocity readings if pipe dope gets on the sensor electrodes.

- Remove the plastic cover from the pipe nipple on the compression seal and wrap the nipple with teflon tape.
- Screw the compression seal into the ball valve. The restraining rod holes need to be oriented so that they form a line that is parallel to the side of the pipe (Figure 3-6).
- Put the insertion tube back in the compression seal and reinstall the restraining rod. Do not extend the sensor beyond the nipple.
- Check the restraining rod at the compression seal for proper installation. The set screw must be flush with the surface. The flat portion of the restraining rod must be viewed through the inspection hole (Figure 3-7).

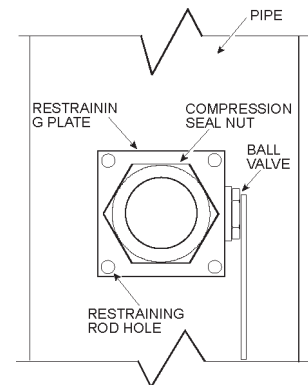

Figure 3-6. Compression Seal Installation

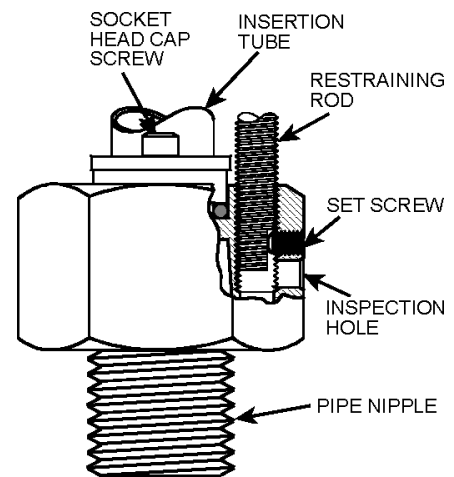

Figure 3-7. Compression Seal

### **WARNING**

*The insertion tube may shoot out of the pipe if the restraining rod is not properly installed.*

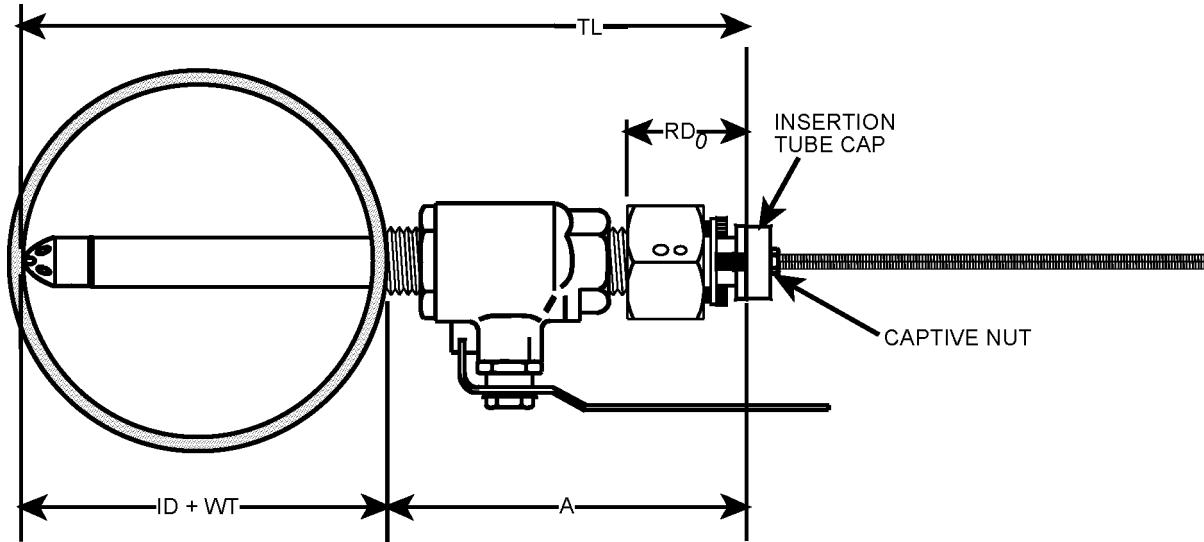

Figure 3-8. Checking Pipe ID

### **IMPORTANT**

*Tighten the socket head cap screws on the compression seal (Figure 3-7) only enough to seal the insertion tube. Tightening the screws too much may cause the seal to grip the insertion tube. This could result in the captive nut (Figure 3-8) being pulled out of the insertion tube cap when the insertion tube is retracted from the pipe.*

### **Check Pipe ID**

If you do not know the inside diameter (ID) and wall thickness (WT) of the pipe, measure them before you start to profile. The best method is to measure them directly; however, if the flow cannot be shut down, the sensor can be used to get these measurements.

- Carefully insert the sensor through only the compression seal.
- Open the ball valve.
- Place a 9/16" box ratchet on the captive nut, and rotate clockwise until the tip of the sensor reaches the far wall of the pipe. The sensor will stop and you will not be able to turn the ratchet.

### **CAUTION**

*As the sensor nears the far wall, slow down and do not force the ratchet. Excessive force could damage the sensor and insertion hardware which would require sensor replacement.*

- Measure the outside circumference of the pipe and divide this measurement by  $\pi$  (3.14). This is the outside diameter (OD).
- Add 1/2" to length C (Figure 3-5). This is total length (TL).
- Measure distance A (Figure 3-8). This is measured from the pipe OD the top edge of the insertion tube cap .
- Subtract distance A from total length (TL). This will give the inside diameter (ID) plus one wall thickness (WT).

$$TL - A = ID + WT$$

- Determine the wall thickness by:

$$WT = OD - (ID + WT)$$

- Determine inside diameter by:

$$ID = OD - 2(WT) \text{ or } ID = (ID + WT) - WT$$

## Measuring the Velocity Profile

### Far Wall Method

The far wall is the wall opposite the sensor mounting hardware. The far wall method starts with the first velocity measurement being taken at the far wall. If the insertion tube is too short to traverse the pipe, use the near wall method (Page 3-9) to do a partial profile (Section IV).

*Comment:*

*The far wall method is preferred because it is easier to locate the far wall than it is the near wall.*

*The sensor cable must be connected to the flowmeter and the meter must be set to output velocity. Check the flowmeter instruction manual for sensor cable connection and velocity output.*

To obtain the velocity profile, you will need to measure multiple velocities at various locations across the pipe. To do this you need:

A reference distance (RD).

The profiling data log at the back of this manual.

The reference distance is measured from the top edge of the insertion tube cap to the bottom edge of the compression seal nut (Figure 3-9).



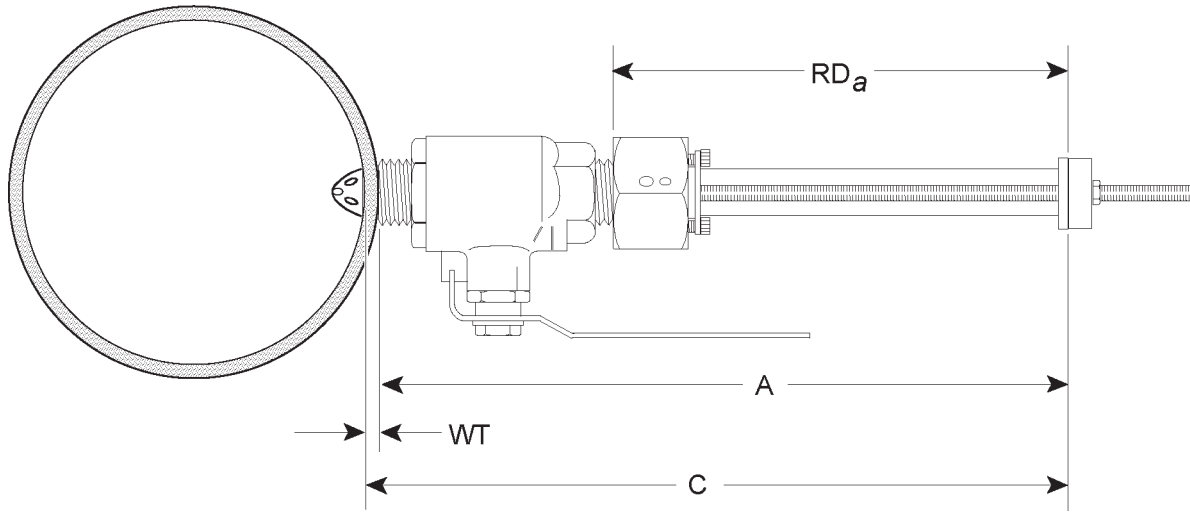

- Make a copy of the page in the profiling data log that is marked with the inside diameter (ID) of your pipe.
- Position the sensor at the far wall ( $RD_0$ ) by rotating the captive nut on the insertion tube cap clockwise until the sensor stops (Figure 3-8). Slow down as the sensor approaches the far wall and do not force the ratchet.

PIPE ID = 2.25"		# OF DATA POINTS 6		
REF (RD)	SENSOR	MEASURED	WEIGHT	WEIGHTED
DISTANCE	LOCATION	VELOCITY (FPS)	CONSTANT	VELOCITY
RD <sub>6</sub> _____	0.00	_____	x 2.771	= _____
RD <sub>5</sub> _____	0.25	_____	x 0.598	= _____
RD <sub>4</sub> _____	0.50	_____	x 0.249	= _____
RD <sub>3</sub> _____	0.75	_____	x 0.083	= _____
RD <sub>2</sub> _____	1.00	_____	x 0.613	= _____
RD <sub>1</sub> _____	1.50	_____	x 1.717	= _____
RD <sub>0</sub> _____			TOTAL	_____
TOTAL _____ ÷ 6.52 = MEAN VEL _____				

*Comment:*

*The profiling data log is in the back of this manual. Make a copy of the appropriate page and use the copy to do the profile.*

Figure 3-10. Profiling Data Log

- Measure (RD<sub>0</sub>) and write it down in the bottom of the (RD) column.
- Rotate the captive nut on the insertion tube cap counter-clockwise until (RD<sub>1</sub>) is reached.

$$RD_1 = (RD_0 + 1/4'')$$

- Record (RD<sub>1</sub>) and the velocity reading in the appropriate columns at the bottom of the log at (RD<sub>1</sub>) location (Figure 3-10).

- Position the sensor at (RD<sub>2</sub>). Record (RD<sub>2</sub>) and the velocity.

$$RD_2 = (\text{Sensor Location } RD_1 - \text{Sensor Location } RD_2) + RD_1$$

- Position the sensor at (RD<sub>3</sub>). Record (RD<sub>3</sub>) and the velocity.

$$RD_3 = (\text{Sensor Location } RD_2 - \text{Sensor Location } RD_3) + RD_2$$

- Repeat this until you reach sensor location 0.00.

### Sensor Location Check

The sensor location check is used to verify the pipe ID. With the sensor at location 0.00, increase distance (RD) by 1/2". This should retract the sensor into the ball valve and cause the velocity to drop to zero. If the velocity is not zero, then the ID is larger than thought. If the velocity drops to near zero before location 0.00 is reached, the ID is smaller than thought.

### Mean Velocity ( $\bar{U}$ ) Calculation

After you have finished profiling, you need to calculate the mean velocity ( $\bar{U}$ ).

- Multiply each measured velocity by the weight constant and record the product in weighted velocity column.
- Now add the weighted velocities and record the total in the TOTAL block.
- Divide the total by the number specified on the bottom of the log to find the mean velocity.

$$TOTAL \underline{\hspace{2cm}} \div XX.XX = MEAN VEL$$

### Velocity Multiplier (K1, K2, K3)

The Velocity Multiplier (K) converts the sensed velocity to a mean velocity. For all flowmeters that use the Flo-Ware program, the velocity multiplier is calculated by that program. Check the Flo-Ware Communications User manual for a description of the velocity multiplier fields. For those flowmeters which do not use the Flo-Ware program, the velocity multiplier calculation is as follows:

- Position the sensor at the operating position and record the velocity.
- Divide the mean velocity that was recorded in the profiling data log by the operating position velocity. The result is Velocity Multiplier (K).

*Comment:*

*If you want to do a second or third order correction (Page 1-3), you must use the Site-Ware program. You can also consult the factory.*

*The flow at the time the profile is done and the flow at the time the velocity multiplier is calculated must be the same.*

### Sensor Operating Position (Raw Waste Water)

The operation position for raw waste water and sludge is at sensor location 0.00. To position the sensor at this location you need to:

- Calculate distance A (Figure 3-11) by subtracting the pipe wall thickness (WT) from length C (Figure 3-5).
- Position the top edge of the insertion tube cap distanced A (Figure 3-11) from the pipe.

### Sensor Operating Position (Clean Water)

The preferred operating position for clean water that does not contain rags or strings is at the 1/8 D sensor position (Page 3-12).

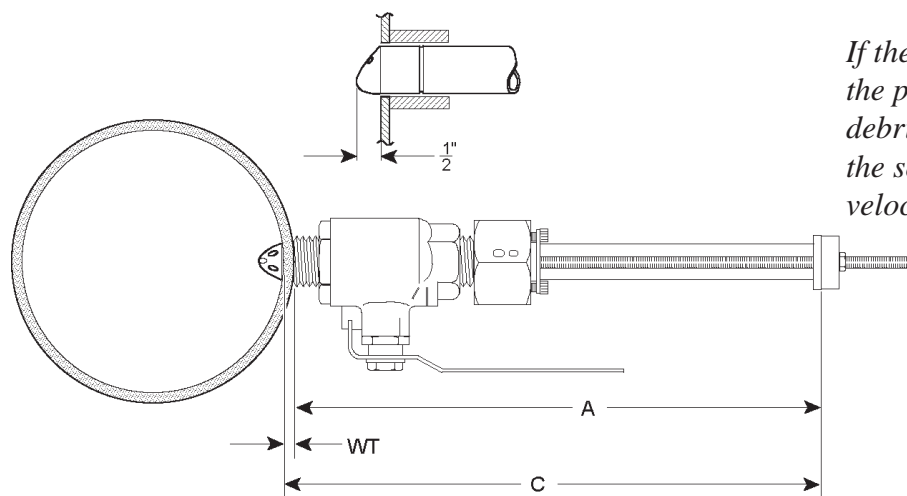

*If the sensor protrudes into the pipe past the taper, debris could collect on the sensor and affect the velocity readings*

Figure 3-11. Sensor Operating Position

# Measuring the Velocity Profile

## Near Wall Method

The near wall is the wall through which the sensor enters the pipe. With the near wall method, the first velocity measurement is taken when the sensor is located at the near wall.

*Comment:*

*The far wall method is preferred because it is easier to locate the far wall than it is the near wall.*

*The sensor cable must be connected to the flowmeter and the meter must be set to output velocity. Check the flowmeter instruction manual for sensor cable connection and velocity output.*

To measure the velocity profile, you will need to measure the velocity at various locations across the pipe. To do this you need:

A reference distance (RD).

The profiling data log at the back of this manual.

The reference distance is measured from the top edge of the insertion tube cap to the bottom edge of the compression seal nut (Figure 3-12).

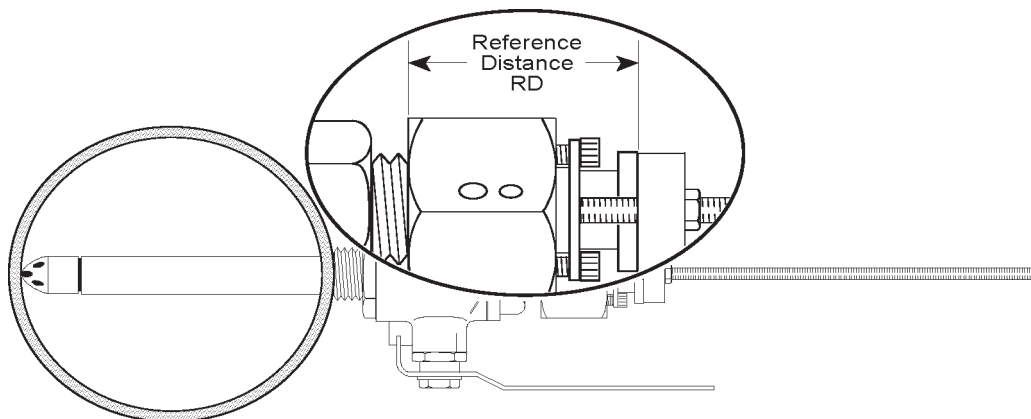

Figure 3-12. Reference Distance RD

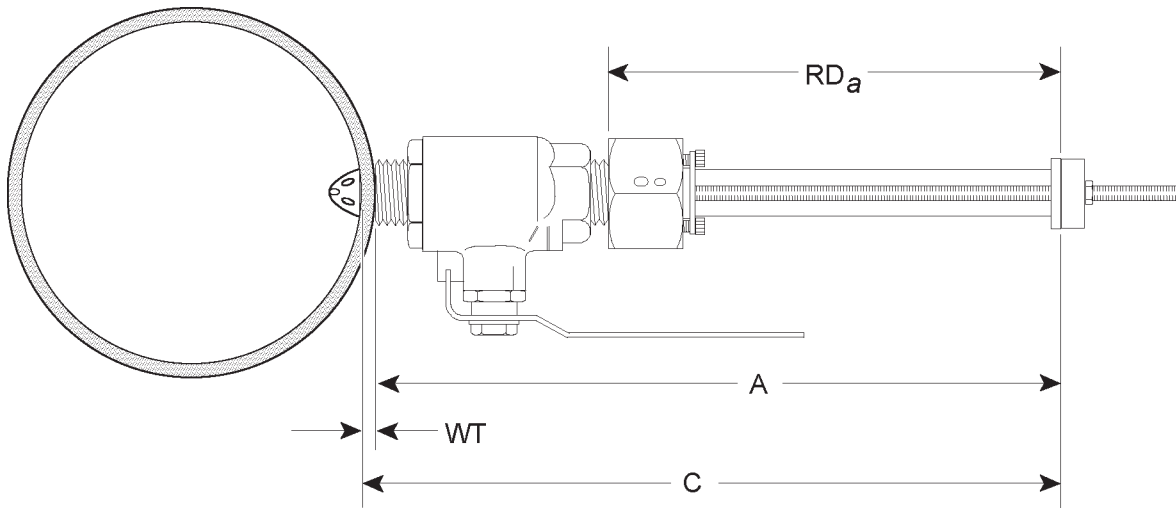

Figure 3-13.  $RD_a$  Near Wall

- Make a copy of the page in the profiling data log that is marked with the inside diameter (ID) of your pipe.
- Calculate distance A (Figure 3-11) by subtracting the wall thickness (WT) from length C.
- With a ratchet, rotate the captive nut on the insertion tube cap until the top edge of the insertion tube cap is distance A from the pipe. This is sensor position  $RD_a$ .
- Measure reference distance  $RD_a$  (Figure 3-13) and record it at sensor location 0.00 under the reference distance column in the profiling data log (Figure 3-14).
- Record the velocity in the Measured Velocity column next to sensor location 0.00.
- Calculate  $RD_b$  and rotate the captive nut clockwise until  $RD_b$  is reached.  

$$RD_b = RD_a - (\text{Sensor Location } RD_b - \text{Sensor Location } RD_a)$$
- Record  $RD_b$  and the velocity in the appropriate columns.
- Calculate  $RD_c$  and rotate the captive nut clockwise until  $RD_c$  is reached.  

$$RD_c = RD_b - (\text{Sensor Location } RD_c - \text{Sensor Location } RD_b)$$
- Record  $RD_c$  and the velocity in the appropriate columns.
- Repeat this until you reach the bottom sensor location.

PIPE ID = 2.25"		# OF DATA POINTS 8		
REF (RD) DISTANCE	SENSOR LOCATION	MEASURED VELOCITY (FPS)	WEIGHT CONSTANT	WEIGHTED VELOCITY
RD <sub>a</sub> _____	0.00	_____	x 2.771	= _____
RD <sub>b</sub> _____	0.25	_____	x 0.598	= _____
RD <sub>c</sub> _____	0.50	_____	x 0.249	= _____
RD <sub>d</sub> _____	0.75	_____	x 0.083	= _____
RD <sub>e</sub> _____	1.00	_____	x 0.613	= _____
RD <sub>f</sub> _____	1.50	_____	x 1.717	= _____
			TOTAL	_____
TOTAL _____		÷ 19.25 = MEAN VEL _____		

*Comment:*

*The profiling data log is in the back of this manual. Make a copy of the appropriate page and use the copy to do the profile.*

Figure 3-14. Profiling Data Log

### Sensor Location Check

The sensor location check is used to verify the pipe ID. After you have reached the bottom location, decrease distance RD by 1/4". The sensor should stop. Do not force the captive nut. If the sensor stops before the 1/4" distance is reached, then the ID is smaller than thought. If the sensor does not stop when the 1/4" distance is reached, then the ID is larger than thought.

*Comment:*

*A mistake in sensor positioning during the profile could also produce errors. Make sure the sensor is in the proper positions when profiling.*

### CAUTION

*Do not force the captive nut. This could damage the sensor and insertion hardware.*

### Mean Velocity ( $\bar{U}$ ) Calculation

After you have finished profiling you need to calculate the mean velocity.

- Multiply each measured velocity by the weight constant and record the product in the Weighted Velocity column.

- Add the weighted velocities and record the total at the bottom of the page in the TOTAL block.
- Divide the total by the number specified on the bottom of the log to find the mean velocity.

$$TOTAL \underline{\hspace{2cm}} \div XX.XX = MEAN VEL$$

### Velocity Multiplier (K1, K2, K3) Calculation

Calculate the velocity multiplier as described on Page 3-7.

### Sensor Operating Position

The operating position for raw waste water and sludge is at sensor location 0.00 (Page 3-8). The operating position for clean water is at the 1/8 D position (Page 3-12).

## 1/8 D Profile

The accuracy of a 1/8 D profile depends on the existence of a theoretical profile (Page 1-2), and should only be used when the profile is symmetrical or like the theoretical. An industry accepted standard is that the velocity of the flow at a distance of 1/8 the diameter from the wall of the pipe is considered to be the mean velocity. To profile, simply position the sensor at 1/8 D and record the velocity. Then calculate the velocity multiplier (Page 3-7).

### 1/8 D Sensor Position

- Find Tube Length (TL)(Figure 3-15).

$$TL = C + \frac{1}{2}''$$

- Calculate (1/8 D).

$$\frac{D}{8} = .125 \times \text{Pipe ID}$$

- Add wall thickness to 1/8 D.
- Calculate distance A (Figure 3-16).

$$A = TL - (1/8 D + WT)$$

**The tip of the sensor will be at 1/8 D.**

*Figure 3-15. Tube Length (TL)*

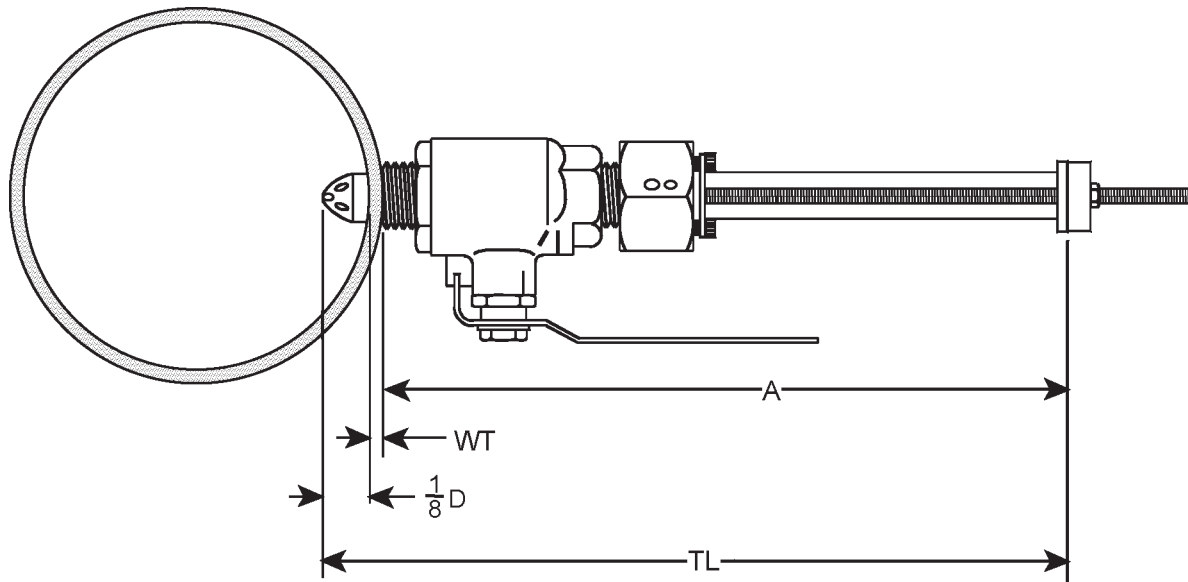

Figure 3-16. 1/8 D Sensor Position

- Set the top edge of the insertion tube cap distance (A) from the pipe.
- Record the velocity and calculate the velocity multiplier (Page 3-7).

If the flow is clean water, the sensor can be left at the 1/8 D position. At this position, the sensed and mean velocity are equal and  $K = 1$ . Do not leave the sensor in this position for raw waste water because debris could collect on the sensor and affect the velocity readings. In waste water applications, position the sensor at location 0.00 (Page 3-8).



# OPTIONS

## Cable Disconnect Option

The cable disconnect is used on both the sensor and pressure cables. To connect the cable, align the latch alignment marks and push the connector together. To disconnect the cable, pull the latch release toward the cable.

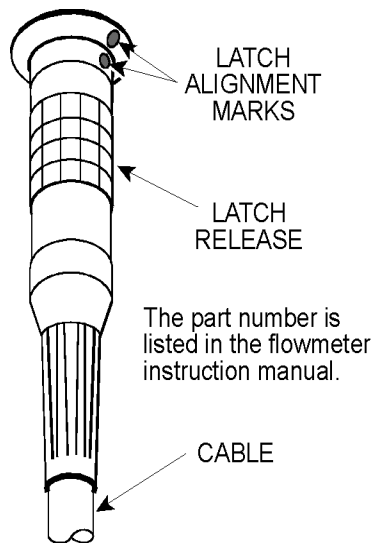

Figure 3-17. Cable Disconnect

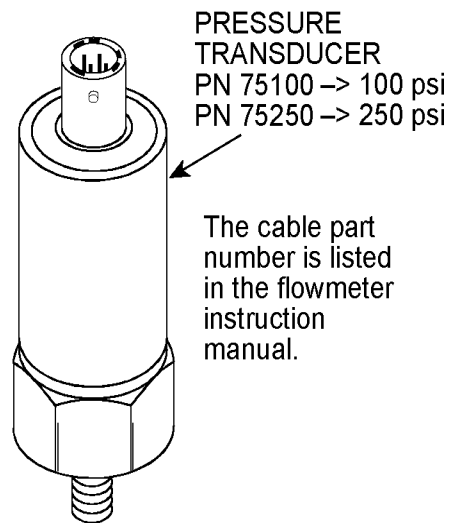

Figure 3-18. Pressure Transducer

*Comment:*

*The cable disconnect is not available on all flowmeters.*

## Pressure Options

The 1" full pipe sensor insertion hardware can be configured with a 100 psi pressure transducer.

*Comment:*

*The pressure option is not available on all instruments. If the option is available, the instrument instruction manual will contain the information that describes how to connect the pressure cable to the flowmeter.*

Pressure transducer installation.

- Retract the sensor past the ball valve and close the valve.
- Remove the plug in the pressure port (Figure 3-17) on the compression seal.
- Wrap the pressure transducer threads with teflon tape and screw into the pressure port.
- Connect the cable to the pressure transducer and flowmeter.
- Open the ball valve and position the sensor at the operating position.

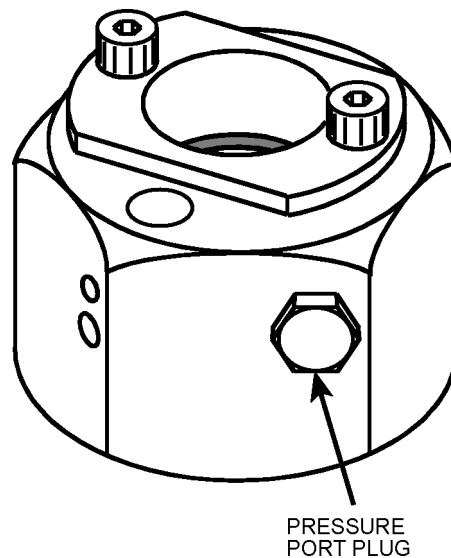

*Figure 3-19. Pressure Port*

## ONE INCH FULL PIPE SENSOR PARTS ILLUSTRATION

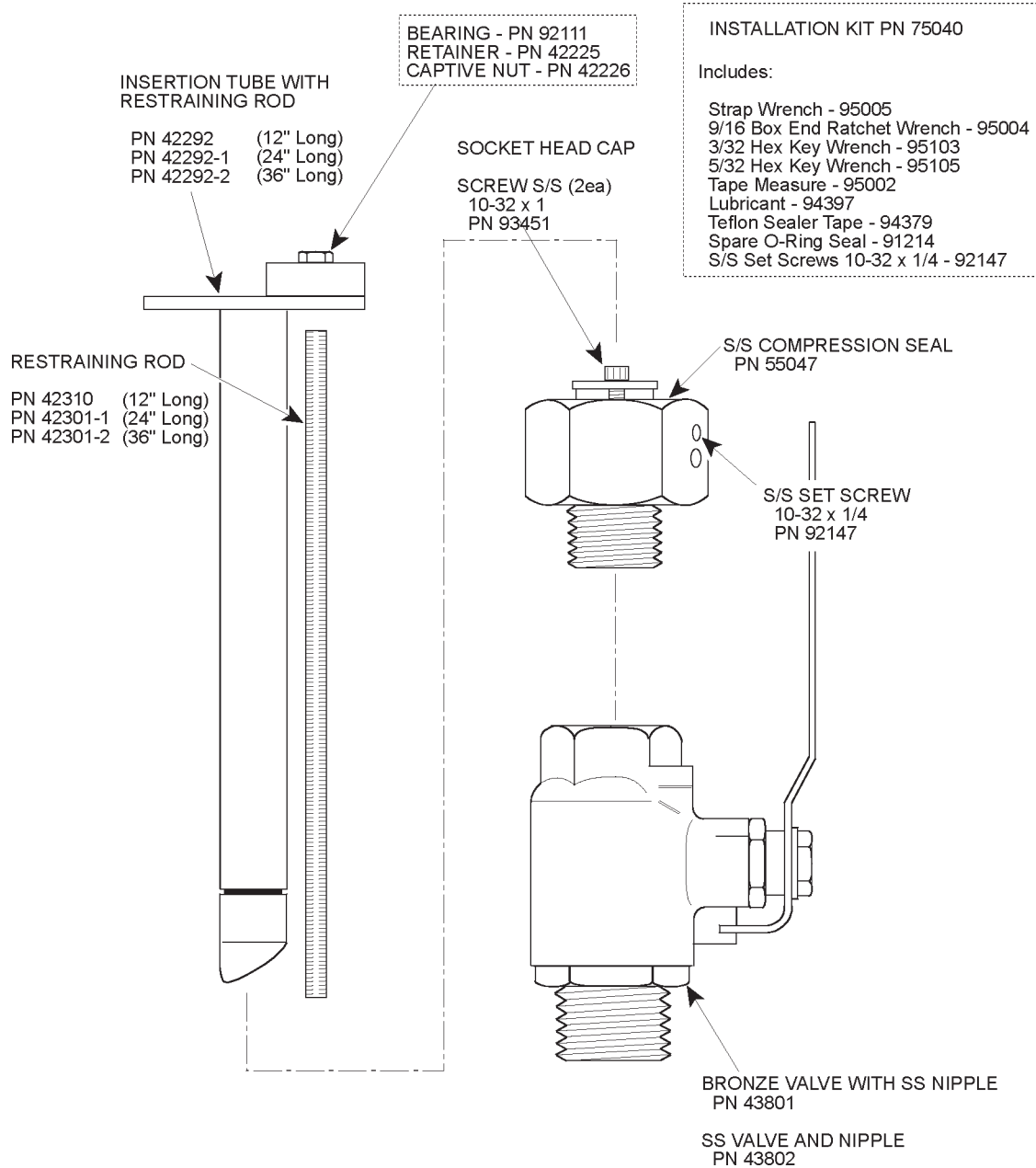

## SECTION IV

## PARTIAL PROFILES

In an application where it is difficult to measure a complete velocity profile, a partial profile can be used to estimate a complete profile. The mean velocity can then be calculated from the estimated profile. The accuracy of this technique however, is dependent upon experience with fluid dynamics. Do not use the partial profile as a substitute for the complete profile. Use the partial profile when:

- The insertion tube is too short to traverse the pipe.
- A constant flow rate cannot be maintained long enough to do a full profile.
- The combination of a long insertion tube and high velocity causes excessive sensor vibration.

Partial profiling requires that the user be familiar with the type of profiles that can be expected when the sensor is inserted into a pipe (Figure 4-1). Elbows or obstructions cause distorted profiles and make estimation difficult. This problem can be avoided by locating the sensor a distance of five diameters upstream or ten diameters downstream from obstructions or elbows.

Notice that the expected profile is not symmetrical about the center line. The insertion tube partially

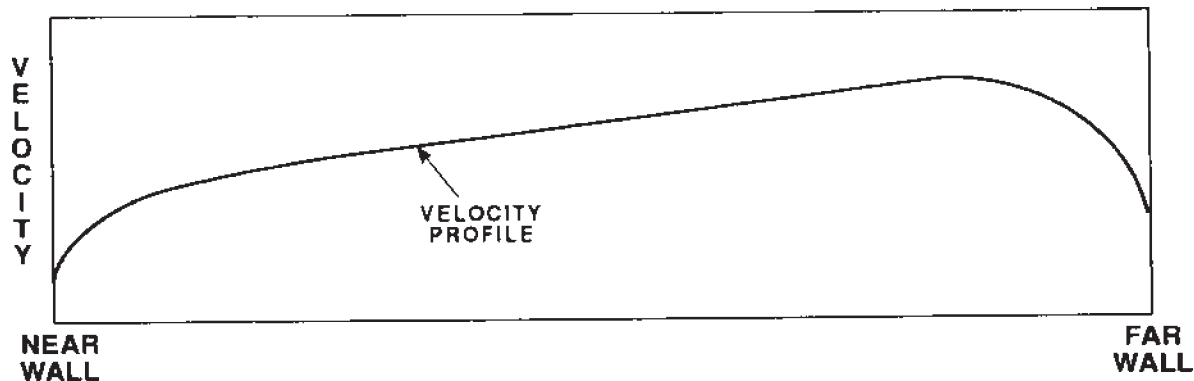

Figure 4-1. Expected Profile

obstructs the conduit causing the fluid to speed up. The speeding up effect is less noticeable in the larger diameter conduits.

### Partial Profiling Methods

#### Every other point method:

Measure and record the point velocity at every other sensor location (See profiling data log for sensor location values). This will cut the profiling time in half.

**60% method:**

Measure and record the point velocities across 60% of the pipe diameter.

**Combination method:**

Measure and record the point velocity at every other sensor location across 60% of the pipe diameter.

## Profile Curve Estimation

To estimate the profile, you need to:

- Measure the partial profile and record these velocities in the profiling data log. As a minimum, try to traverse 60% of the pipe diameter at every other sensor location. The more points you measure, the easier it will be to estimate the profile curve.
- Plot the measured velocities on a graph. Mark the vertical axis velocity and the horizontal axis sensor location.
- Calculate far/near wall velocity.
- Draw a smooth curve connecting the near and far wall velocities. Use the partial profile and the expected profile to estimate the profile curve.
- Find the missing velocities on the curve and record them in the profiling data log.

With either the far wall (Page 3-5) or near wall (Page 3-9) profiling method, measure as many point velocities as you can and plot them on a graph (Figure 4-2).

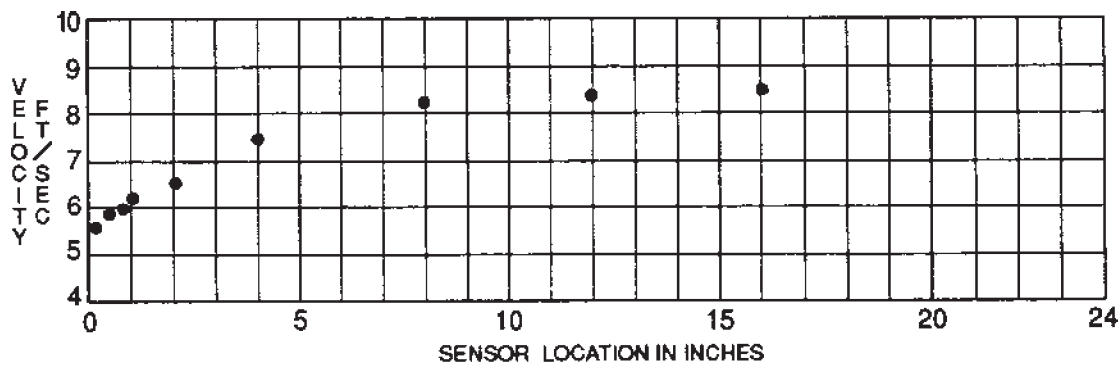

Figure 4-2. Partial Profile Plot (24" Diameter)

## Far/Near Wall Sensor Location Velocities

There is approximately an 18% difference between the far wall and near wall sensor location velocities. The far wall velocity is faster than the near wall velocity. Calculate by:

- $1.18 \times \text{near wall velocity} = \text{far wall velocity}$ .
- $0.85 \times \text{far wall velocity} = \text{near wall velocity}$ .

Plot the far/near wall sensor location velocity points.

## Complete The Profile Curve

Draw a continuous curve of the complete profile. Estimate the curve where the velocity points are missing. The estimation is based on the expected profile (Figure 4-3).

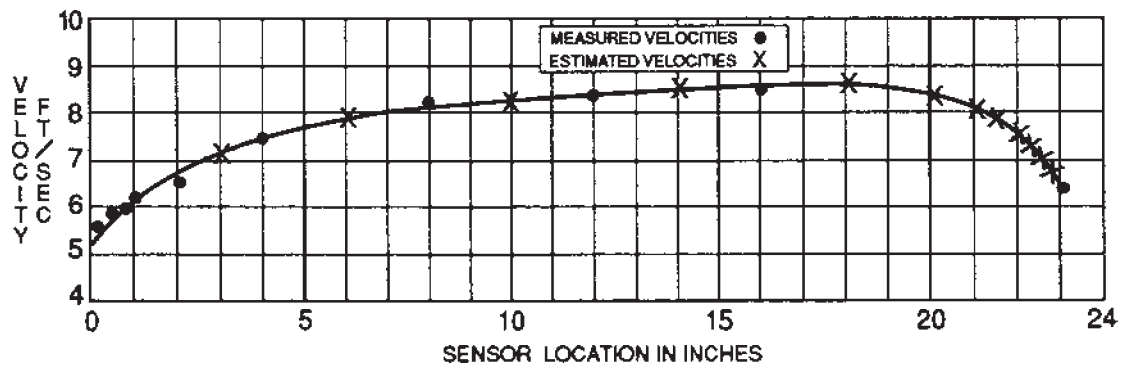

Figure 4-3. Complete Profile Curve (24" Diameter)

Notice that the curve does not cover the complete diameter of the pipe. This is because the sensor locations in the profiling data log are used as points of reference to plot the estimated curve. Actual velocity position is from 0.75" to 23.75".

Find the missing velocity points on the profile curve. From the graph, read the velocity values at these points and record them in the profiling data log. You may want to highlight the estimated velocity values for future reference. Calculate the mean velocity as described on Page 3-7.

2.00 - 2.25

PIPE ID = 2.00" # OF DATA POINTS 5					PIPE ID = 2.25" # OF DATA POINTS 6				
REF (RD) DISTANCE	SENSOR LOCATION	MEASURED VELOCITY (FPS)	WEIGHT CONSTANT	WEIGHTED VELOCITY	REF (RD) DISTANCE	SENSOR LOCATION	MEASURED VELOCITY (FPS)	WEIGHT CONSTANT	WEIGHTED VELOCITY
_____	0.00	_____	x 2.313	= _____	_____	0.00	_____	x 2.771	= _____
_____	0.25	_____	x 0.410	= _____	_____	0.25	_____	x 0.598	= _____
_____	0.50	_____	x 0.084	= _____	_____	0.50	_____	x 0.249	= _____
_____	0.75	_____	x 0.211	= _____	_____	0.75	_____	x 0.083	= _____
_____	1.00	_____	x 1.735	= _____	_____	1.00	_____	x 0.613	= _____
			TOTAL	_____				TOTAL	_____
TOTAL _____ ÷ 5.23 = MEAN VEL _____					TOTAL _____ ÷ 6.64 = MEAN VEL _____				

PIPE ID = 2.50"      # OF DATA POINTS 7					PIPE ID = 2.75"      # OF DATA POINTS 8				
REF (RD) DISTANCE	SENSOR LOCATION	MEASURED VELOCITY (FPS)	WEIGHT CONSTANT	WEIGHTED VELOCITY	REF (RD) DISTANCE	SENSOR LOCATION	MEASURED VELOCITY (FPS)	WEIGHT CONSTANT	WEIGHTED VELOCITY
_____	0.00	_____	x 3.228	= _____	_____	0.00	_____	x 3.683	= _____
_____	0.25	_____	x 0.791	= _____	_____	0.25	_____	x 0.986	= _____
_____	0.50	_____	x 0.416	= _____	_____	0.50	_____	x 0.600	= _____
_____	0.75	_____	x 0.088	= _____	_____	0.75	_____	x 0.256	= _____
_____	1.00	_____	x 0.452	= _____	_____	1.00	_____	x 0.244	= _____
_____	1.50	_____	x 0.966	= _____	_____	1.50	_____	x 0.843	= _____
_____	1.75	_____	x 1.725	= _____	_____	1.75	_____	x 0.863	= _____
_____			TOTAL	_____	_____	2.00	_____	x 2.025	= _____
								TOTAL	_____
TOTAL _____ ÷ 8.22 = MEAN VEL _____					TOTAL _____ ÷ 9.97 = MEAN VEL _____				

2.50 - 2.75



3.00 - 3.25

PIPE ID = 3.00"      # OF DATA POINTS 8					PIPE ID = 3.25"      # OF DATA POINTS 9				
REF (RD) DISTANCE	SENSOR LOCATION	MEASURED VELOCITY (FPS)	WEIGHT CONSTANT	WEIGHTED VELOCITY	REF (RD) DISTANCE	SENSOR LOCATION	MEASURED VELOCITY (FPS)	WEIGHT CONSTANT	WEIGHTED VELOCITY
_____	0.00	_____	x 4.136	= _____	_____	0.00	_____	x 4.588	= _____
_____	0.25	_____	x 1.183	= _____	_____	0.25	_____	x 1.381	= _____
_____	0.50	_____	x 0.790	= _____	_____	0.50	_____	x 0.982	= _____
_____	0.75	_____	x 0.423	= _____	_____	0.75	_____	x 0.606	= _____
_____	1.00	_____	x 0.091	= _____	_____	1.00	_____	x 0.262	= _____
_____	1.50	_____	x 1.130	= _____	_____	1.50	_____	x 0.792	= _____
_____	2.00	_____	x 1.433	= _____	_____	2.00	_____	x 1.308	= _____
_____	2.25	_____	x 2.331	= _____	_____	2.25	_____	x 1.188	= _____
_____			TOTAL	_____	_____	2.50	_____	x 2.643	= _____
								TOTAL	_____
TOTAL _____ ÷ 11.90 = MEAN VEL _____					TOTAL _____ ÷ 14.01 = MEAN VEL _____				

PIPE ID = 3.50" # OF DATA POINTS 10					PIPE ID = 3.75" # OF DATA POINTS 11				
REF (RD) DISTANCE	SENSOR LOCATION	MEASURED VELOCITY (FPS)	WEIGHT CONSTANT	WEIGHTED VELOCITY	REF (RD) DISTANCE	SENSOR LOCATION	MEASURED VELOCITY (FPS)	WEIGHT CONSTANT	WEIGHTED VELOCITY
_____	0.00	_____	x 5.039	= _____	_____	0.00	_____	x 5.489	= _____
_____	0.25	_____	x 1.580	= _____	_____	0.25	_____	x 1.778	= _____
_____	0.50	_____	x 1.177	= _____	_____	0.50	_____	x 1.373	= _____
_____	0.75	_____	x 0.793	= _____	_____	0.75	_____	x 0.984	= _____
_____	1.00	_____	x 0.525	= _____	_____	1.00	_____	x 0.884	= _____
_____	1.50	_____	x 0.496	= _____	_____	1.50	_____	x 0.260	= _____
_____	2.00	_____	x 1.143	= _____	_____	2.00	_____	x 0.948	= _____
_____	2.25	_____	x 1.107	= _____	_____	2.25	_____	x 1.000	= _____
_____	2.50	_____	x 0.356	= _____	_____	2.50	_____	x 1.272	= _____
_____	2.75	_____	x 2.958	= _____	_____	2.75	_____	x 1.528	= _____
_____			TOTAL	_____	_____			TOTAL	_____
TOTAL _____ ÷ 16.30 = MEAN VEL _____					TOTAL _____ ÷ 18.76 = MEAN VEL _____				

3.50 - 3.75

4.00 - 4.25

PIPE ID = 4.00"      # OF DATA POINTS 9					PIPE ID = 4.25"      # OF DATA POINTS 10				
REF (RD) DISTANCE	SENSOR LOCATION	MEASURED VELOCITY (FPS)	WEIGHT CONSTANT	WEIGHTED VELOCITY	REF (RD) DISTANCE	SENSOR LOCATION	MEASURED VELOCITY (FPS)	WEIGHT CONSTANT	WEIGHTED VELOCITY
_____	0.00	_____	x 5.939	= _____	_____	0.00	_____	x 6.387	= _____
_____	0.25	_____	x 1.977	= _____	_____	0.25	_____	x 2.176	= _____
_____	0.50	_____	x 1.569	= _____	_____	0.50	_____	x 1.767	= _____
_____	0.75	_____	x 1.176	= _____	_____	0.75	_____	x 1.370	= _____
_____	1.00	_____	x 1.064	= _____	_____	1.00	_____	x 1.346	= _____
_____	1.50	_____	x 0.266	= _____	_____	1.50	_____	x 0.530	= _____
_____	2.00	_____	x 2.287	= _____	_____	2.00	_____	x 1.759	= _____
_____	3.00	_____	x 3.700	= _____	_____	3.00	_____	x 3.454	= _____
_____	3.25	_____	x 3.600	= _____	_____	3.25	_____	x 1.879	= _____
_____			TOTAL	_____	_____			TOTAL	_____
TOTAL _____ ÷ 21.41 = MEAN VEL _____					TOTAL _____ ÷ 24.24 = MEAN VEL _____				

PIPE ID = 4.50"      # OF DATA POINTS 11					PIPE ID = 4.75"      # OF DATA POINTS 12				
REF (RD) DISTANCE	SENSOR LOCATION	MEASURED VELOCITY (FPS)	WEIGHT CONSTANT	WEIGHTED VELOCITY	REF (RD) DISTANCE	SENSOR LOCATION	MEASURED VELOCITY (FPS)	WEIGHT CONSTANT	WEIGHTED VELOCITY
_____	0.00	_____	x 6.835	= _____	_____	0.00	_____	x 7.283	= _____
_____	0.25	_____	x 2.375	= _____	_____	0.25	_____	x 2.574	= _____
_____	0.50	_____	x 1.964	= _____	_____	0.50	_____	x 2.162	= _____
_____	0.75	_____	x 1.566	= _____	_____	0.75	_____	x 1.762	= _____
_____	1.00	_____	x 1.632	= _____	_____	1.00	_____	x 1.920	= _____
_____	1.50	_____	x 0.889	= _____	_____	1.50	_____	x 1.344	= _____
_____	2.00	_____	x 1.284	= _____	_____	2.00	_____	x 0.873	= _____
_____	3.00	_____	x 3.163	= _____	_____	3.00	_____	x 2.836	= _____
_____	3.25	_____	x 1.786	= _____	_____	3.25	_____	x 1.674	= _____
_____	3.50	_____	x 2.057	= _____	_____	3.50	_____	x 1.961	= _____
_____	3.75	_____	x 4.251	= _____	_____	3.75	_____	x 2.237	= _____
_____			TOTAL	_____	_____	4.00	_____	x 4.579	= _____
								TOTAL	_____
TOTAL _____ ÷ 27.25 = MEAN VEL _____					TOTAL _____ ÷ 30.45 = MEAN VEL _____				

4.50 - 4.75

5.00 - 5.25

PIPE ID = 5.00" # OF DATA POINTS 13					PIPE ID = 5.25" # OF DATA POINTS 13				
REF (RD) DISTANCE	SENSOR LOCATION	MEASURED VELOCITY (FPS)	WEIGHT CONSTANT	WEIGHTED VELOCITY	REF (RD) DISTANCE	SENSOR LOCATION	MEASURED VELOCITY (FPS)	WEIGHT CONSTANT	WEIGHTED VELOCITY
_____	0.00	_____	x 7.729	= _____	_____	0.00	_____	x 8.176	= _____
_____	0.25	_____	x .772	= _____	_____	0.25	_____	x 2.971	= _____
_____	0.50	_____	x 2.361	= _____	_____	0.50	_____	x 2.559	= _____
_____	0.75	_____	x 1.958	= _____	_____	0.75	_____	x 2.155	= _____
_____	1.00	_____	x 2.210	= _____	_____	1.00	_____	x 2.502	= _____
_____	1.50	_____	x 1.615	= _____	_____	1.50	_____	x 1.992	= _____
_____	2.00	_____	x 0.273	= _____	_____	2.00	_____	x 0.541	= _____
_____	3.00	_____	x 2.988	= _____	_____	3.00	_____	x 3.040	= _____
_____	3.25	_____	x 1.549	= _____	_____	3.50	_____	x 2.461	= _____
_____	3.50	_____	x 1.848	= _____	_____	3.75	_____	x 2.024	= _____
_____	3.75	_____	x 2.138	= _____	_____	4.00	_____	x 2.317	= _____
_____	4.00	_____	x 2.419	= _____	_____	4.25	_____	x 2.601	= _____
_____	4.25	_____	x 4.909	= _____	_____	4.50	_____	x 5.240	= _____
				TOTAL _____					TOTAL _____
TOTAL _____ ÷ 33.84 = MEAN VEL _____					TOTAL _____ ÷ 37.41 = MEAN VEL _____				

PIPE ID = 5.50"      # OF DATA POINTS 14					PIPE ID = 7.50"      # OF DATA POINTS 14				
REF (RD) DISTANCE	SENSOR LOCATION	MEASURED VELOCITY (FPS)	WEIGHT CONSTANT	WEIGHTED VELOCITY	REF (RD) DISTANCE	SENSOR LOCATION	MEASURED VELOCITY (FPS)	WEIGHT CONSTANT	WEIGHTED VELOCITY
_____	0.00	_____	x 8.622	= _____	_____	0.00	_____	x 9.068	= _____
_____	0.25	_____	x 3.169	= _____	_____	0.25	_____	x 3.368	= _____
_____	0.50	_____	x 2.757	= _____	_____	0.50	_____	x 2.956	= _____
_____	0.75	_____	x 2.353	= _____	_____	0.75	_____	x 2.550	= _____
_____	1.00	_____	x 2.794	= _____	_____	1.00	_____	x 3.088	= _____
_____	1.50	_____	x 2.371	= _____	_____	1.50	_____	x 2.754	= _____
_____	2.00	_____	x 0.904	= _____	_____	2.00	_____	x 1.362	= _____
_____	3.00	_____	x 2.402	= _____	_____	3.00	_____	x 1.827	= _____
_____	3.50	_____	x 2.253	= _____	_____	3.50	_____	x 2.880	= _____
_____	3.75	_____	x 1.897	= _____	_____	4.00	_____	x 2.986	= _____
_____	4.00	_____	x 2.201	= _____	_____	4.25	_____	x 2.379	= _____
_____	4.25	_____	x 2.497	= _____	_____	4.50	_____	x 2.678	= _____
_____	4.50	_____	x 2.785	= _____	_____	4.75	_____	x 2.970	= _____
_____	4.75	_____	x 5.572	= _____	_____	5.00	_____	x 5.905	= _____
_____			TOTAL _____		_____			TOTAL _____	
TOTAL _____ ÷ 41.17 = MEAN VEL _____					TOTAL _____ ÷ 45.12 = MEAN VEL _____				

5.50 - 5.75

6.00 - 6.25

PIPE ID = 6.00"      # OF DATA POINTS 14					PIPE ID = 6.25"      # OF DATA POINTS 14				
REF (RD) DISTANCE	SENSOR LOCATION	MEASURED VELOCITY (FPS)	WEIGHT CONSTANT	WEIGHTED VELOCITY	REF (RD) DISTANCE	SENSOR LOCATION	MEASURED VELOCITY (FPS)	WEIGHT CONSTANT	WEIGHTED VELOCITY
_____	0.00	_____	x 9.513	= _____	_____	0.00	_____	x 9.959	= _____
_____	0.25	_____	x 3.566	= _____	_____	0.25	_____	x 3.764	= _____
_____	0.50	_____	x 3.154	= _____	_____	0.50	_____	x 3.352	= _____
_____	0.75	_____	x 2.748	= _____	_____	0.75	_____	x 2.946	= _____
_____	1.00	_____	x 3.382	= _____	_____	1.00	_____	x 3.677	= _____
_____	1.50	_____	x 3.139	= _____	_____	1.50	_____	x 3.525	= _____
_____	2.00	_____	x 1.916	= _____	_____	2.00	_____	x 2.567	= _____
_____	3.00	_____	x 2.459	= _____	_____	3.00	_____	x 1.865	= _____
_____	4.00	_____	x 4.209	= _____	_____	4.00	_____	x 4.861	= _____
_____	4.25	_____	x 2.251	= _____	_____	4.50	_____	x 3.519	= _____
_____	4.50	_____	x 2.559	= _____	_____	4.75	_____	x 2.740	= _____
_____	4.75	_____	x 2.861	= _____	_____	5.00	_____	x 3.044	= _____
_____	5.00	_____	x 3.156	= _____	_____	5.25	_____	x 3.343	= _____
_____	5.25	_____	x 6.239	= _____	_____	5.50	_____	x 6.573	= _____
_____			TOTAL	_____	_____			TOTAL	_____
TOTAL _____ ÷ 49.27 = MEAN VEL _____					TOTAL _____ ÷ 53.60 = MEAN VEL _____				

PIPE ID = 6.50" # OF DATA POINTS 15					PIPE ID = 6.75" # OF DATA POINTS 15				
REF (RD) DISTANCE	SENSOR LOCATION	MEASURED VELOCITY (FPS)	WEIGHT CONSTANT	WEIGHTED VELOCITY	REF (RD) DISTANCE	SENSOR LOCATION	MEASURED VELOCITY (FPS)	WEIGHT CONSTANT	WEIGHTED VELOCITY
_____	0.00	_____	x 10.404	= _____	_____	0.00	_____	x 10.848	= _____
_____	0.25	_____	x 3.963	= _____	_____	0.25	_____	x 4.161	= _____
_____	0.50	_____	x 3.550	= _____	_____	0.50	_____	x 3.749	= _____
_____	0.75	_____	x 3.144	= _____	_____	0.75	_____	x 3.342	= _____
_____	1.00	_____	x 3.972	= _____	_____	1.00	_____	x 4.267	= _____
_____	1.50	_____	x 3.914	= _____	_____	1.50	_____	x 4.303	= _____
_____	2.00	_____	x 3.316	= _____	_____	2.00	_____	x 4.163	= _____
_____	3.00	_____	x 1.346	= _____	_____	3.00	_____	x 0.908	= _____
_____	4.00	_____	x 4.399	= _____	_____	4.00	_____	x 3.920	= _____
_____	4.50	_____	x 3.310	= _____	_____	4.50	_____	x 4.291	= _____
_____	4.75	_____	x 2.609	= _____	_____	5.00	_____	x 4.058	= _____
_____	5.00	_____	x 2.922	= _____	_____	5.25	_____	x 3.104	= _____
_____	5.25	_____	x 3.228	= _____	_____	5.50	_____	x 3.414	= _____
_____	5.50	_____	x 3.530	= _____	_____	5.75	_____	x 3.718	= _____
_____	5.75	_____	x 6.908	= _____	_____	6.00	_____	x 7.244	= _____
_____			TOTAL	_____	_____			TOTAL	_____
TOTAL _____ ÷ 58.13 = MEAN VEL _____					TOTAL _____ ÷ 62.86 = MEAN VEL _____				

6.50 - 6.75



7.00 - 7.25

PIPE ID = 7.00"      # OF DATA POINTS 16					PIPE ID = 7.25"      # OF DATA POINTS 15				
REF (RD) DISTANCE	SENSOR LOCATION	MEASURED VELOCITY (FPS)	WEIGHT CONSTANT	WEIGHTED VELOCITY	REF (RD) DISTANCE	SENSOR LOCATION	MEASURED VELOCITY (FPS)	WEIGHT CONSTANT	WEIGHTED VELOCITY
_____	0.00	_____	x 11.293	= _____	_____	0.00	_____	x 11.737	= _____
_____	0.25	_____	x 4.359	= _____	_____	0.25	_____	x 4.557	= _____
_____	0.50	_____	x 3.947	= _____	_____	0.50	_____	x 4.145	= _____
_____	0.75	_____	x 3.540	= _____	_____	0.75	_____	x 3.738	= _____
_____	1.00	_____	x 4.563	= _____	_____	1.00	_____	x 4.859	= _____
_____	1.50	_____	x 4.694	= _____	_____	1.50	_____	x 5.085	= _____
_____	2.00	_____	x 4.170	= _____	_____	2.00	_____	x 4.745	= _____
_____	3.00	_____	x 0.914	= _____	_____	3.00	_____	x 1.347	= _____
_____	4.00	_____	x 3.966	= _____	_____	4.00	_____	x 4.883	= _____
_____	4.50	_____	x 3.988	= _____	_____	5.00	_____	x 6.995	= _____
_____	5.00	_____	x 3.848	= _____	_____	5.50	_____	x 4.603	= _____
_____	5.25	_____	x 2.972	= _____	_____	5.70	_____	x 3.472	= _____
_____	5.50	_____	x 3.288	= _____	_____	6.00	_____	x 3.786	= _____
_____	5.75	_____	x 3.599	= _____	_____	6.25	_____	x 4.095	= _____
_____	6.00	_____	x 3.906	= _____	_____	6.50	_____	x 7.918	= _____
_____	6.25	_____	x 7.581	= _____	_____			TOTAL _____	
_____				TOTAL _____					
				TOTAL _____ ÷ 67.78 = MEAN VEL _____					TOTAL _____ ÷ 72.90 = MEAN VEL _____

REF (RD) DISTANCE	SENSOR LOCATION	MEASURED VELOCITY (FP S)	WEIGHT CONSTANT	WEIGHTED VELOCITY
_____	0.00	_____	x 12.182 =	_____
_____	0.25	_____	x 4.754 =	_____
_____	0.50	_____	x 4.343 =	_____
_____	0.75	_____	x 3.936 =	_____
_____	1.00	_____	x 5.155 =	_____
_____	1.50	_____	x 5.477 =	_____
_____	2.00	_____	x 5.323 =	_____
_____	3.00	_____	x 1.929 =	_____
_____	4.00	_____	x 4.026 =	_____
_____	5.00	_____	x 6.535 =	_____
_____	5.50	_____	x 4.391 =	_____
_____	5.75	_____	x 3.337 =	_____
_____	6.00	_____	x 3.657 =	_____
_____	6.25	_____	x 3.973 =	_____
_____	6.50	_____	x 4.284 =	_____
_____	6.75	_____	x 8.255 =	_____
_____			TOTAL _____	
TOTAL _____ ÷ 78.22 = MEAN VEL _____				
PIPE ID = 7.75" # OF DATA POINTS 16				

REF (RD) DISTANCE	SENSOR LOCATION	MEASURED VELOCITY (FPS)	WEIGHT CONSTANT	WEIGHTED VELOCITY
_____	0.00	_____	x 12.626 =	_____
_____	0.25	_____	x 4.952 =	_____
_____	0.50	_____	x 4.541 =	_____
_____	0.75	_____	x 4.133 =	_____
_____	1.00	_____	x 5.451 =	_____
_____	1.50	_____	x 5.869 =	_____
_____	2.00	_____	x 5.902 =	_____
_____	3.00	_____	x 2.580 =	_____
_____	4.00	_____	x 3.244 =	_____
_____	5.00	_____	x 6.061 =	_____
_____	5.50	_____	x 5.733 =	_____
_____	6.00	_____	x 5.153 =	_____
_____	6.25	_____	x 3.843 =	_____
_____	6.50	_____	x 4.160 =	_____
_____	6.75	_____	x 4.474 =	_____
_____	7.00	_____	x 8.593 =	_____
_____			TOTAL _____	
TOTAL _____ ÷ 83.73 = MEAN VEL _____				
PIPE ID = 8.00" # OF DATA POINTS 15				

7.50 - 7.75

8.00 - 8.25

REF (RD) DISTANCE	SENSOR LOCATION	MEASURED VELOCITY (FPS)	WEIGHT CONSTANT	WEIGHTED VELOCITY	REF (RD) DISTANCE	SENSOR LOCATION	MEASURED VELOCITY (FPS)	WEIGHT CONSTANT	WEIGHTED VELOCITY
_____	0.00	_____	x 13.070	= _____	_____	0.00	_____	x 13.514	= _____
_____	0.25	_____	x 5.150	= _____	_____	0.25	_____	x 5.348	= _____
_____	0.50	_____	x 4.739	= _____	_____	0.50	_____	x 4.937	= _____
_____	0.75	_____	x 4.331	= _____	_____	0.75	_____	x 4.529	= _____
_____	1.00	_____	x 5.748	= _____	_____	1.00	_____	x 6.044	= _____
_____	1.50	_____	x 6.262	= _____	_____	1.50	_____	x 6.655	= _____
_____	2.00	_____	x 6.484	= _____	_____	2.00	_____	x 7.066	= _____
_____	3.00	_____	x 3.328	= _____	_____	3.00	_____	x 4.174	= _____
_____	4.00	_____	x 5.971	= _____	_____	4.00	_____	x 5.004	= _____
_____	6.00	_____	x 12.476	= _____	_____	6.00	_____	x 13.536	= _____
_____	6.25	_____	x 3.706	= _____	_____	6.50	_____	x 5.707	= _____
_____	6.50	_____	x 4.029	= _____	_____	6.75	_____	x 4.216	= _____
_____	6.75	_____	x 4.349	= _____	_____	7.00	_____	x 4.537	= _____
_____	7.00	_____	x 4.664	= _____	_____	7.25	_____	x 4.855	= _____
_____	7.25	_____	x 8.931	= _____	_____	7.50	_____	x 9.269	= _____
_____			TOTAL	_____	_____			TOTAL	_____
TOTAL _____ ÷ 89.45 = MEAN VEL _____					TOTAL _____ ÷ 95.37 = MEAN VEL _____				
PIPE ID = 8.25" # OF DATA POINTS 15					PIPE ID = 8.50" # OF DATA POINTS 16				

REF (RD) DISTANCE	SENSOR LOCATION	MEASURED VELOCITY (FPS)	WEIGHT CONSTANT	WEIGHTED VELOCITY	
_____	0.00	_____	x 13.957	=	_____
_____	0.25	_____	x 5.545	=	_____
_____	0.50	_____	x 5.135	=	_____
_____	0.75	_____	x 4.727	=	_____
_____	1.00	_____	x 6.340	=	_____
_____	1.50	_____	x 7.049	=	_____
_____	2.00	_____	x 7.650	=	_____
_____	3.00	_____	x 5.117	=	_____
=	_____	_____	_____	_____	_____
_____	4.00	_____	x 4.115	=	_____
_____	6.00	_____	x 12.754	=	_____
_____	6.50	_____	x 5.490	=	_____
_____	6.75	_____	x 4.077	=	_____
_____	7.00	_____	x 4.403	=	_____
_____	7.25	_____	x 4.726	=	_____
_____	7.50	_____	x 5.046	=	_____
_____	7.75	_____	x 9.608	=	_____
_____			TOTAL		_____
TOTAL _____ ÷ 101.49 = MEAN VEL _____					

PIPE ID = 8.75" # OF DATA POINTS 16					
REF (RD) DISTANCE	SENSOR LOCATION	MEASURED VELOCITY (FPS)	WEIGHT CONSTANT	WEIGHTED VELOCITY	
_____	0.00	_____	x 14.401	=	_____
_____	0.25	_____	x 5.743	=	_____
_____	0.50	_____	x 5.332	=	_____
_____	0.75	_____	x 4.925	=	_____
_____	1.00	_____	x 6.637	=	_____
_____	1.50	_____	x 7.443	=	_____
_____	2.00	_____	x 8.235	=	_____
_____	3.00	_____	x 6.158	=	_____
_____	4.00	_____	x 3.309	=	_____
_____	6.00	_____	x 11.952	=	_____
_____	6.50	_____	x 7.197	=	_____
_____	7.00	_____	x 6.264	=	_____
_____	7.25	_____	x 4.591	=	_____
_____	7.50	_____	x 4.915	=	_____
_____	7.75	_____	x 5.237	=	_____
_____	8.00	_____	x 9.947	=	_____
_____			TOTAL		_____
TOTAL _____ ÷ 107.82 = MEAN VEL _____					

8.50 - 8.75



PIPE ID = 9.50"      # OF DATA POINTS 17					PIPE ID = 9.75"      # OF DATA POINTS 17				
REF (RD) DISTANCE	SENSOR LOCATION	MEASURED VELOCITY (FPS)	WEIGHT CONSTANT	WEIGHTED VELOCITY	REF (RD) DISTANCE	SENSOR LOCATION	MEASURED VELOCITY (FPS)	WEIGHT CONSTANT	WEIGHTED VELOCITY
_____	0.00	_____	x 15.731	= _____	_____	0.00	_____	x 16.175	= _____
_____	0.25	_____	x 6.335	= _____	_____	0.25	_____	x 6.532	= _____
_____	0.50	_____	x 5.925	= _____	_____	0.50	_____	x 6.123	= _____
_____	0.75	_____	x 5.518	= _____	_____	0.75	_____	x 5.716	= _____
_____	1.00	_____	x 7.526	= _____	_____	1.00	_____	x 7.822	= _____
_____	1.50	_____	x 8.625	= _____	_____	1.50	_____	x 9.020	= _____
_____	2.00	_____	x 9.995	= _____	_____	2.00	_____	x 10.583	= _____
_____	3.00	_____	x 7.887	= _____	_____	3.00	_____	x 8.658	= _____
_____	4.00	_____	x 1.956	= _____	_____	4.00	_____	x 2.612	= _____
_____	6.00	_____	x 13.780	= _____	_____	6.00	_____	x 12.307	= _____
_____	7.00	_____	x 10.910	= _____	_____	7.00	_____	x 10.434	= _____
_____	7.50	_____	x 6.604	= _____	_____	7.50	_____	x 8.679	= _____
_____	7.75	_____	x 4.825	= _____	_____	8.00	_____	x 7.387	= _____
_____	8.00	_____	x 5.156	= _____	_____	8.25	_____	x 5.346	= _____
_____	8.25	_____	x 5.486	= _____	_____	8.50	_____	x 5.676	= _____
_____	8.50	_____	x 5.812	= _____	_____	8.75	_____	x 6.004	= _____
_____	8.75	_____	x 10.965	= _____	_____	9.00	_____	x 11.305	= _____
_____			TOTAL	_____	_____			TOTAL	_____
TOTAL _____ ÷ 128.02 = MEAN VEL _____					TOTAL _____ ÷ 135.17 = MEAN VEL _____				

9.50 - 9.75

10.00 - 10.25

PIPE ID = 10.00"      # OF DATA POINTS 18					PIPE ID = 10.25"      # OF DATA POINTS 17				
REF (RD) DISTANCE	SENSOR LOCATION	MEASURED VELOCITY (FPS)	WEIGHT CONSTANT	WEIGHTED VELOCITY	REF (RD) DISTANCE	SENSOR LOCATION	MEASURED VELOCITY (FPS)	WEIGHT CONSTANT	WEIGHTED VELOCITY
_____	0.00	_____	x 16.618	= _____	_____	0.00	_____	x 17.061	= _____
_____	0.25	_____	x 6.730	= _____	_____	0.25	_____	x 6.927	= _____
_____	0.50	_____	x 6.320	= _____	_____	0.50	_____	x 6.518	= _____
_____	0.75	_____	x 5.914	= _____	_____	0.75	_____	x 6.111	= _____
_____	1.00	_____	x 8.119	= _____	_____	1.00	_____	x 8.415	= _____
_____	1.50	_____	x 9.414	= _____	_____	1.50	_____	x 9.809	= _____
_____	2.00	_____	x 11.171	= _____	_____	2.00	_____	x 11.760	= _____
_____	3.00	_____	x 9.431	= _____	_____	3.00	_____	x 10.205	= _____
_____	4.00	_____	x 3.365	= _____	_____	4.00	_____	x 4.214	= _____
_____	6.00	_____	x 10.906	= _____	_____	6.00	_____	x 9.582	= _____
_____	7.00	_____	x 9.948	= _____	_____	7.00	_____	x 13.325	= _____
_____	7.50	_____	x 8.369	= _____	_____	8.00	_____	x 13.604	= _____
_____	8.00	_____	x 7.164	= _____	_____	8.50	_____	x 7.952	= _____
_____	8.25	_____	x 5.201	= _____	_____	8.75	_____	x 5.725	= _____
_____	8.50	_____	x 5.535	= _____	_____	9.00	_____	x 6.058	= _____
_____	8.75	_____	x 5.867	= _____	_____	9.25	_____	x 6.389	= _____
_____	9.00	_____	x 6.197	= _____	_____	9.50	_____	x 11.985	= _____
_____	9.25	_____	x 11.645	= _____	_____				TOTAL _____
				TOTAL _____					TOTAL _____
				TOTAL _____ ÷ 142.53 = MEAN VEL _____					TOTAL _____ ÷ 150.10 = MEAN VEL _____

PIPE ID = 10.50"      # OF DATA POINTS 18					PIPE ID = 10.75"      # OF DATA POINTS 18				
REF (RD) DISTANCE	SENSOR LOCATION	MEASURED VELOCITY (FPS)	WEIGHT CONSTANT	WEIGHTED VELOCITY	REF (RD) DISTANCE	SENSOR LOCATION	MEASURED VELOCITY (FPS)	WEIGHT CONSTANT	WEIGHTED VELOCITY
_____	0.00	_____	x 17.504	= _____	_____	0.00	_____	x 17.947	= _____
_____	0.25	_____	x 7.124	= _____	_____	0.25	_____	x 7.321	= _____
_____	0.50	_____	x 6.715	= _____	_____	0.50	_____	x 6.913	= _____
_____	0.75	_____	x 6.309	= _____	_____	0.75	_____	x 6.506	= _____
_____	1.00	_____	x 8.711	= _____	_____	1.00	_____	x 9.008	= _____
_____	1.50	_____	x 10.204	= _____	_____	1.50	_____	x 10.598	= _____
_____	2.00	_____	x 12.349	= _____	_____	2.00	_____	x 12.939	= _____
_____	3.00	_____	x 10.981	= _____	_____	3.00	_____	x 11.759	= _____
_____	4.00	_____	x 5.160	= _____	_____	4.00	_____	x 6.203	= _____
_____	6.00	_____	x 8.336	= _____	_____	6.00	_____	x 7.171	= _____
_____	7.00	_____	x 12.658	= _____	_____	7.00	_____	x 11.982	= _____
_____	8.00	_____	x 13.135	= _____	_____	8.00	_____	x 12.656	= _____
_____	8.50	_____	x 7.727	= _____	_____	8.50	_____	x 10.175	= _____
_____	8.75	_____	x 5.579	= _____	_____	9.00	_____	x 8.519	= _____
_____	9.00	_____	x 5.915	= _____	_____	9.25	_____	x 6.106	= _____
_____	9.25	_____	x 6.250	= _____	_____	9.50	_____	x 6.441	= _____
_____	9.50	_____	x 6.582	= _____	_____	9.75	_____	x 6.775	= _____
_____	9.75	_____	x 12.326	= _____	_____	10.00	_____	x 12.666	= _____
_____			TOTAL	_____	_____			TOTAL	_____
TOTAL _____ ÷ 157.87 = MEAN VEL _____					TOTAL _____ ÷ 165.86 = MEAN VEL _____				

10.50 - 10.75



11.00 - 11.25

PIPE ID = 11.00"      # OF DATA POINTS 19					PIPE ID = 11.25"      # OF DATA POINTS 17				
REF (RD) DISTANCE	SENSOR LOCATION	MEASURED VELOCITY (FPS)	WEIGHT CONSTANT	WEIGHTED VELOCITY	REF (RD) DISTANCE	SENSOR LOCATION	MEASURED VELOCITY (FPS)	WEIGHT CONSTANT	WEIGHTED VELOCITY
_____	0.00	_____	x 18.390	= _____	_____	0.00	_____	x 18.833	= _____
_____	0.25	_____	x 7.518	= _____	_____	0.25	_____	x 7.716	= _____
_____	0.50	_____	x 7.110	= _____	_____	0.50	_____	x 7.308	= _____
_____	0.75	_____	x 6.704	= _____	_____	0.75	_____	x 6.901	= _____
_____	1.00	_____	x 9.304	= _____	_____	1.00	_____	x 9.600	= _____
_____	1.50	_____	x 10.993	= _____	_____	1.50	_____	X 11.388	= _____
_____	2.00	_____	x 13.529	= _____	_____	2.00	_____	X 14.119	= _____
_____	3.00	_____	x 12.537	= _____	_____	3.00	_____	X 13.317	= _____
_____	4.00	_____	x 7.345	= _____	_____	4.00	_____	x 8.583	= _____
_____	6.00	_____	x 6.088	= _____	_____	6.00	_____	x 9.707	= _____
_____	7.00	_____	x 11.297	= _____	_____	8.00	_____	X 22.260	= _____
_____	8.00	_____	x 12.168	= _____	_____	9.00	_____	X 15.853	= _____
_____	8.50	_____	x 9.862	= _____	_____	9.50	_____	x 9.088	= _____
_____	9.00	_____	x 8.293	= _____	_____	9.75	_____	x 6.487	= _____
_____	9.25	_____	x 5.958	= _____	_____	10.00	_____	x 6.825	= _____
_____	9.50	_____	x 6.297	= _____	_____	10.25	_____	x 7.161	= _____
_____	9.75	_____	x 6.633	= _____	_____	10.50	_____	X 13.347	= _____
_____	10.00	_____	x 6.986	= _____	_____				TOTAL _____
_____	10.25	_____	x 13.007	= _____	_____				
_____				TOTAL _____	_____				
				TOTAL _____ ÷ 174.06 = MEAN VEL _____					TOTAL _____ ÷ 182.47 = MEAN VEL _____

PIPE ID = 11.50"      # OF DATA POINTS 18					PIPE ID = 11.75"      # OF DATA POINTS 18				
REF (RD) DISTANCE	SENSOR LOCATION	MEASURED VELOCITY (FPS)	WEIGHT CONSTANT	WEIGHTED VELOCITY	REF (RD) DISTANCE	SENSOR LOCATION	MEASURED VELOCITY (FPS)	WEIGHT CONSTANT	WEIGHTED VELOCITY
_____	0.00	_____	X 19.276	= _____	_____	0.00	_____	X 19.719	= _____
_____	0.25	_____	x 7.913	= _____	_____	0.25	_____	x 8.110	= _____
_____	0.50	_____	x 7.505	= _____	_____	0.50	_____	x 7.702	= _____
_____	0.75	_____	x 7.099	= _____	_____	0.75	_____	x 7.296	= _____
_____	1.00	_____	x 9.896	= _____	_____	1.00	_____	X 10.193	= _____
_____	1.50	_____	X 11.783	= _____	_____	1.50	_____	X 12.178	= _____
_____	2.00	_____	X 14.709	= _____	_____	2.00	_____	X 15.299	= _____
_____	3.00	_____	X 14.097	= _____	_____	3.00	_____	X 14.878	= _____
_____	4.00	_____	x 9.920	= _____	_____	4.00	_____	X 11.355	= _____
_____	6.00	_____	x 8.437	= _____	_____	6.00	_____	x 7.252	= _____
_____	8.00	_____	X 21.252	= _____	_____	8.00	_____	X 20.231	= _____
_____	9.00	_____	X 15.379	= _____	_____	9.00	_____	X 14.896	= _____
_____	9.50	_____	x 8.860	= _____	_____	9.50	_____	X 11.681	= _____
_____	9.75	_____	x 6.338	= _____	_____	10.00	_____	x 9.659	= _____
_____	10.00	_____	x 6.679	= _____	_____	10.25	_____	x 6.870	= _____
_____	10.25	_____	x 7.017	= _____	_____	10.50	_____	x 7.210	= _____
_____	10.50	_____	x 7.354	= _____	_____	10.75	_____	x 7.548	= _____
_____	10.75	_____	X 13.688	= _____	_____	11.00	_____	X 14.029	= _____
_____			TOTAL _____		_____			TOTAL _____	
TOTAL _____ ÷ 191.09 = MEAN VEL _____					TOTAL _____ ÷ 199.93 = MEAN VEL _____				

11.50 - 11.75

12.00 - 12.25

PIPE ID = 12.00"      # OF DATA POINTS 19					PIPE ID = 12.25"      # OF DATA POINTS 18				
REF (RD) DISTANCE	SENSOR LOCATION	MEASURED VELOCITY (FPS)	WEIGHT CONSTANT	WEIGHTED VELOCITY	REF (RD) DISTANCE	SENSOR LOCATION	MEASURED VELOCITY (FPS)	WEIGHT CONSTANT	WEIGHTED VELOCITY
_____	0.00	_____	X 20.162	= _____	_____	0.00	_____	X 20.604	= _____
_____	0.25	_____	x 8.307	= _____	_____	0.25	_____	x 8.504	= _____
_____	0.50	_____	x 7.899	= _____	_____	0.50	_____	x 8.097	= _____
_____	0.75	_____	x 7.494	= _____	_____	0.75	_____	x 7.691	= _____
_____	1.00	_____	X 10.489	= _____	_____	1.00	_____	X 10.785	= _____
_____	1.50	_____	X 12.572	= _____	_____	1.50	_____	X 12.967	= _____
_____	2.00	_____	X 15.890	= _____	_____	2.00	_____	X 16.481	= _____
_____	3.00	_____	X 15.660	= _____	_____	3.00	_____	X 16.443	= _____
_____	4.00	_____	X 12.888	= _____	_____	4.00	_____	X 14.519	= _____
_____	6.00	_____	x 6.153	= _____	_____	6.00	_____	x 5.141	= _____
_____	8.00	_____	X 19.198	= _____	_____	8.00	_____	X 18.155	= _____
_____	9.00	_____	X 14.406	= _____	_____	9.00	_____	X 19.273	= _____
_____	9.50	_____	X 11.365	= _____	_____	10.00	_____	X 18.116	= _____
_____	10.00	_____	x 9.428	= _____	_____	10.50	_____	X 10.230	= _____
_____	10.25	_____	x 6.719	= _____	_____	10.75	_____	x 7.253	= _____
_____	10.50	_____	x 7.061	= _____	_____	11.00	_____	x 7.595	= _____
_____	10.75	_____	x 7.402	= _____	_____	11.25	_____	x 7.935	= _____
_____	11.00	_____	x 7.741	= _____	_____	11.50	_____	X 14.712	= _____
_____	11.25	_____	X 14.371	= _____	_____			TOTAL _____	
_____			TOTAL _____		_____			TOTAL _____	
TOTAL _____ ÷ 208.98 = MEAN VEL _____					TOTAL _____ ÷ 218.24 = MEAN VEL _____				

PIPE ID = 12.50"      # OF DATA POINTS 19					PIPE ID = 12.75"      # OF DATA POINTS 19				
REF (RD) DISTANCE	SENSOR LOCATION	MEASURED VELOCITY (FPS)	WEIGHT CONSTANT	WEIGHTED VELOCITY	REF (RD) DISTANCE	SENSOR LOCATION	MEASURED VELOCITY (FPS)	WEIGHT CONSTANT	WEIGHTED VELOCITY
_____	0.00	_____	X 21.047	= _____	_____	0.00	_____	X 21.490	= _____
_____	0.25	_____	x 8.701	= _____	_____	0.25	_____	x 8.898	= _____
_____	0.50	_____	x 8.294	= _____	_____	0.50	_____	x 8.491	= _____
_____	0.75	_____	x 7.888	= _____	_____	0.75	_____	x 8.086	= _____
_____	1.00	_____	X 11.081	= _____	_____	1.00	_____	X 11.377	= _____
_____	1.50	_____	X 13.362	= _____	_____	1.50	_____	X 13.757	= _____
_____	2.00	_____	X 17.072	= _____	_____	2.00	_____	X 17.663	= _____
_____	3.00	_____	X 17.226	= _____	_____	3.00	_____	X 18.010	= _____
_____	4.00	_____	X 16.248	= _____	_____	4.00	_____	X 18.076	= _____
_____	6.00	_____	x 4.217	= _____	_____	6.00	_____	x 3.383	= _____
_____	8.00	_____	X 17.103	= _____	_____	8.00	_____	X 16.041	= _____
_____	9.00	_____	X 18.605	= _____	_____	9.00	_____	X 17.928	= _____
_____	10.00	_____	X 17.638	= _____	_____	10.00	_____	X 17.152	= _____
_____	10.50	_____	x 9.998	= _____	_____	10.50	_____	X 13.197	= _____
_____	10.75	_____	x 7.101	= _____	_____	11.00	_____	X 10.803	= _____
_____	11.00	_____	x 7.445	= _____	_____	11.25	_____	x 7.637	= _____
_____	11.25	_____	x 7.788	= _____	_____	11.50	_____	x 7.981	= _____
_____	11.50	_____	x 8.129	= _____	_____	11.75	_____	x 8.322	= _____
_____	11.75	_____	X 15.053	= _____	_____	12.00	_____	X 15.394	= _____
_____			TOTAL	_____	_____			TOTAL	_____
TOTAL _____ ÷ 227.72 = MEAN VEL _____					TOTAL _____ ÷ 237.42 = MEAN VEL _____				

12.50 - 12.75



PIPE ID = 13.50"      # OF DATA POINTS 19					PIPE ID = 13.75"      # OF DATA POINTS 19				
REF (RD) DISTANCE	SENSOR LOCATION	MEASURED VELOCITY (FPS)	WEIGHT CONSTANT	WEIGHTED VELOCITY	REF (RD) DISTANCE	SENSOR LOCATION	MEASURED VELOCITY (FPS)	WEIGHT CONSTANT	WEIGHTED VELOCITY
_____	0.00	_____	X 22.818	= _____	_____	0.00	_____	X 23.260	= _____
_____	0.25	_____	x 9.489	= _____	_____	0.25	_____	x 9.686	= _____
_____	0.50	_____	x 9.082	= _____	_____	0.50	_____	x 9.280	= _____
_____	0.75	_____	x 8.677	= _____	_____	0.75	_____	x 8.875	= _____
_____	1.00	_____	X 12.265	= _____	_____	1.00	_____	X 12.561	= _____
_____	1.50	_____	X 14.941	= _____	_____	1.50	_____	X 15.335	= _____
_____	2.00	_____	X 19.436	= _____	_____	2.00	_____	X 20.027	= _____
_____	3.00	_____	X 20.363	= _____	_____	3.00	_____	X 21.148	= _____
_____	4.00	_____	X 18.891	= _____	_____	4.00	_____	X 20.057	= _____
_____	6.00	_____	x 5.189	= _____	_____	6.00	_____	x 6.234	= _____
_____	8.00	_____	X 21.457	= _____	_____	8.00	_____	X 19.548	= _____
_____	10.00	_____	X 30.212	= _____	_____	10.00	_____	X 29.189	= _____
_____	11.00	_____	X 19.909	= _____	_____	11.00	_____	X 19.419	= _____
_____	11.50	_____	X 11.142	= _____	_____	11.50	_____	X 14.719	= _____
_____	11.75	_____	x 7.867	= _____	_____	12.00	_____	X 11.953	= _____
_____	12.00	_____	x 8.214	= _____	_____	12.25	_____	x 8.407	= _____
_____	12.25	_____	x 8.560	= _____	_____	12.50	_____	x 8.753	= _____
_____	12.50	_____	x 8.905	= _____	_____	12.75	_____	x 9.099	= _____
_____	12.75	_____	X 16.419	= _____	_____	13.00	_____	X 16.761	= _____
_____			TOTAL	_____	_____			TOTAL	_____
TOTAL _____ ÷ 267.80 = MEAN VEL _____					TOTAL _____ ÷ 278.36 = MEAN VEL _____				

13.50 - 13.75

14.00 - 14.25

PIPE ID = 14.00"      # OF DATA POINTS 20					PIPE ID = 14.25"      # OF DATA POINTS 19				
REF (RD) DISTANCE	SENSOR LOCATION	MEASURED VELOCITY (FPS)	WEIGHT CONSTANT	WEIGHTED VELOCITY	REF (RD) DISTANCE	SENSOR LOCATION	MEASURED VELOCITY (FPS)	WEIGHT CONSTANT	WEIGHTED VELOCITY
_____	0.00	_____	X 23.703	= _____	_____	0.00	_____	X 24.145	= _____
_____	0.25	_____	x 9.882	= _____	_____	0.25	_____	X 10.079	= _____
_____	0.50	_____	x 9.477	= _____	_____	0.50	_____	x 9.674	= _____
_____	0.75	_____	x 9.072	= _____	_____	0.75	_____	x 9.269	= _____
_____	1.00	_____	X 12.856	= _____	_____	1.00	_____	X 13.152	= _____
_____	1.50	_____	X 15.730	= _____	_____	1.50	_____	X 16.125	= _____
_____	2.00	_____	X 20.618	= _____	_____	2.00	_____	X 21.210	= _____
_____	3.00	_____	X 21.934	= _____	_____	3.00	_____	X 22.720	= _____
_____	4.00	_____	X 21.224	= _____	_____	4.00	_____	X 22.392	= _____
_____	6.00	_____	x 7.376	= _____	_____	6.00	_____	x 8.615	= _____
_____	8.00	_____	X 17.722	= _____	_____	8.00	_____	X 15.981	= _____
_____	10.00	_____	X 28.157	= _____	_____	10.00	_____	X 27.116	= _____
_____	11.00	_____	X 18.924	= _____	_____	11.00	_____	X 25.296	= _____
_____	11.50	_____	X 14.397	= _____	_____	12.00	_____	X 22.678	= _____
_____	12.00	_____	X 11.716	= _____	_____	12.50	_____	X 12.529	= _____
_____	12.25	_____	x 8.251	= _____	_____	12.75	_____	x 8.792	= _____
_____	12.50	_____	x 8.600	= _____	_____	13.00	_____	x 9.140	= _____
_____	12.75	_____	x 8.947	= _____	_____	13.25	_____	x 9.487	= _____
_____	13.00	_____	x 9.293	= _____	_____	13.50	_____	X 17.445	= _____
_____	13.25	_____	X 17.103	= _____	_____			TOTAL	_____
			TOTAL	_____				TOTAL	_____
			TOTAL _____	÷ 289.14 = MEAN VEL _____				TOTAL _____	÷ 300.14 = MEAN VEL _____

PIPE ID = 14.50"      # OF DATA POINTS 20					PIPE ID = 14.75"      # OF DATA POINTS 20				
REF (RD) DISTANCE	SENSOR LOCATION	MEASURED VELOCITY (FPS)	WEIGHT CONSTANT	WEIGHTED VELOCITY	REF (RD) DISTANCE	SENSOR LOCATION	MEASURED VELOCITY (FPS)	WEIGHT CONSTANT	WEIGHTED VELOCITY
_____	0.00	_____	X 24.588 =	_____	_____	0.00	_____	X 25.030 =	_____
_____	0.25	_____	X 10.276 =	_____	_____	0.25	_____	X 10.473 =	_____
_____	0.50	_____	x 9.871 =	_____	_____	0.50	_____	X 10.068 =	_____
_____	0.75	_____	x 9.466 =	_____	_____	0.75	_____	x 9.663 =	_____
_____	1.00	_____	X 13.448 =	_____	_____	1.00	_____	X 13.744 =	_____
_____	1.50	_____	X 16.519 =	_____	_____	1.50	_____	X 16.914 =	_____
_____	2.00	_____	X 21.801 =	_____	_____	2.00	_____	X 22.392 =	_____
_____	3.00	_____	X 23.506 =	_____	_____	3.00	_____	X 24.292 =	_____
_____	4.00	_____	X 23.561 =	_____	_____	4.00	_____	X 24.732 =	_____
_____	6.00	_____	x 9.179 =	_____	_____	6.00	_____	X 11.386 =	_____
_____	8.00	_____	X 14.325 =	_____	_____	8.00	_____	X 12.755 =	_____
_____	10.00	_____	X 26.066 =	_____	_____	10.00	_____	X 25.009 =	_____
_____	11.00	_____	X 24.623 =	_____	_____	11.00	_____	X 23.943 =	_____
_____	12.00	_____	X 22.191 =	_____	_____	12.00	_____	X 21.697 =	_____
_____	12.50	_____	X 12.290 =	_____	_____	12.50	_____	X 16.248 =	_____
_____	12.75	_____	x 8.636 =	_____	_____	13.00	_____	X 13.106 =	_____
_____	13.00	_____	x 8.985 =	_____	_____	13.25	_____	x 9.179 =	_____
_____	13.25	_____	x 9.334 =	_____	_____	13.50	_____	x 9.528 =	_____
_____	13.50	_____	x 9.682 =	_____	_____	13.75	_____	x 9.876 =	_____
_____	13.75	_____	X 17.786 =	_____	_____	14.00	_____	X 18.128 =	_____
_____			TOTAL _____		_____			TOTAL _____	
TOTAL _____ ÷ 311.35 = MEAN VEL _____					TOTAL _____ ÷ 322.78 = MEAN VEL _____				

14.50 - 14.75



15.00 - 15.25

PIPE ID = 15.00" # OF DATA POINTS 21					PIPE ID = 15.25" # OF DATA POINTS 19				
REF (RD) DISTANCE	SENSOR LOCATION	MEASURED VELOCITY (FPS)	WEIGHT CONSTANT	WEIGHTED VELOCITY	REF (RD) DISTANCE	SENSOR LOCATION	MEASURED VELOCITY (FPS)	WEIGHT CONSTANT	WEIGHTED VELOCITY
_____	0.00	_____	X 25.473	= _____	_____	0.00	_____	X 25.915	= _____
_____	0.25	_____	X 10.670	= _____	_____	0.25	_____	X 10.867	= _____
_____	0.50	_____	X 10.265	= _____	_____	0.50	_____	X 10.462	= _____
_____	0.75	_____	x 9.860	= _____	_____	0.75	_____	X 10.058	= _____
_____	1.00	_____	X 14.040	= _____	_____	1.00	_____	X 14.335	= _____
_____	1.50	_____	X 17.308	= _____	_____	1.50	_____	X 17.703	= _____
_____	2.00	_____	X 22.984	= _____	_____	2.00	_____	X 23.575	= _____
_____	3.00	_____	X 25.079	= _____	_____	3.00	_____	X 25.865	= _____
_____	4.00	_____	X 25.903	= _____	_____	4.00	_____	X 27.074	= _____
_____	6.00	_____	X 12.917	= _____	_____	6.00	_____	X 14.547	= _____
_____	8.00	_____	X 11.274	= _____	_____	8.00	_____	x 9.881	= _____
_____	10.00	_____	X 23.945	= _____	_____	10.00	_____	X 33.475	= _____
_____	11.00	_____	X 23.257	= _____	_____	12.00	_____	X 40.286	= _____
_____	12.00	_____	X 21.199	= _____	_____	13.00	_____	X 24.972	= _____
_____	12.50	_____	X 15.922	= _____	_____	13.50	_____	X 13.683	= _____
_____	13.00	_____	X 12.866	= _____	_____	13.75	_____	x 9.565	= _____
_____	13.25	_____	x 9.021	= _____	_____	14.00	_____	x 9.916	= _____
_____	13.50	_____	x 9.372	= _____	_____	14.25	_____	X 10.265	= _____
_____	13.75	_____	x 9.722	= _____	_____	14.50	_____	X 18.812	= _____
_____	14.00	_____	X 10.071	= _____	_____			TOTAL _____	
_____	14.25	_____	X 18.470	= _____				TOTAL _____ ÷ 346.30 = MEAN VEL _____	
_____			TOTAL _____						
			TOTAL _____ ÷ 334.43 = MEAN VEL _____						

PIPE ID = 15.50"      # OF DATA POINTS 20					PIPE ID = 15.75"      # OF DATA POINTS 20				
REF (RD) DISTANCE	SENSOR LOCATION	MEASURED VELOCITY (FPS)	WEIGHT CONSTANT	WEIGHTED VELOCITY	REF (RD) DISTANCE	SENSOR LOCATION	MEASURED VELOCITY (FPS)	WEIGHT CONSTANT	WEIGHTED VELOCITY
_____	0.00	_____	X 26.357	= _____	_____	0.00	_____	X 26.800	= _____
_____	0.25	_____	X 11.063	= _____	_____	0.25	_____	X 11.260	= _____
_____	0.50	_____	X 10.659	= _____	_____	0.50	_____	X 10.855	= _____
_____	0.75	_____	X 10.255	= _____	_____	0.75	_____	X 10.452	= _____
_____	1.00	_____	X 14.631	= _____	_____	1.00	_____	X 14.927	= _____
_____	1.50	_____	X 18.097	= _____	_____	1.50	_____	X 18.492	= _____
_____	2.00	_____	X 24.166	= _____	_____	2.00	_____	X 24.758	= _____
_____	3.00	_____	X 26.652	= _____	_____	3.00	_____	X 27.439	= _____
_____	4.00	_____	X 28.247	= _____	_____	4.00	_____	X 29.420	= _____
_____	6.00	_____	X 16.274	= _____	_____	6.00	_____	X 18.100	= _____
_____	8.00	_____	x 8.577	= _____	_____	8.00	_____	x 7.364	= _____
_____	10.00	_____	X 32.044	= _____	_____	10.00	_____	X 30.605	= _____
_____	12.00	_____	X 39.267	= _____	_____	12.00	_____	X 38.239	= _____
_____	13.00	_____	X 24.481	= _____	_____	13.00	_____	X 23.984	= _____
_____	13.50	_____	X 13.442	= _____	_____	13.50	_____	X 17.781	= _____
_____	13.75	_____	x 9.406	= _____	_____	14.00	_____	X 14.261	= _____
_____	14.00	_____	x 9.758	= _____	_____	14.25	_____	x 9.952	= _____
_____	14.25	_____	X 10.110	= _____	_____	14.50	_____	X 10.304	= _____
_____	14.50	_____	X 10.460	= _____	_____	14.75	_____	X 10.655	= _____
_____	14.75	_____	X 19.155	= _____	_____	15.00	_____	X 19.497	= _____
_____			TOTAL _____		_____			TOTAL _____	
TOTAL _____ ÷ 358.39 = MEAN VEL _____					TOTAL _____ ÷ 370.69 = MEAN VEL _____				

15.50 - 15.75

16.00 - 16.25

PIPE ID = 16.00"      # OF DATA POINTS 21					PIPE ID = 16.25"      # OF DATA POINTS 20				
REF (RD) DISTANCE	SENSOR LOCATION	MEASURED VELOCITY (FPS)	WEIGHT CONSTANT	WEIGHTED VELOCITY	REF (RD) DISTANCE	SENSOR LOCATION	MEASURED VELOCITY (FPS)	WEIGHT CONSTANT	WEIGHTED VELOCITY
_____	0.00	_____	X 27.242	= _____	_____	0.00	_____	X 27.685	= _____
_____	0.25	_____	X 11.457	= _____	_____	0.25	_____	X 11.654	= _____
_____	0.50	_____	X 11.052	= _____	_____	0.50	_____	X 11.249	= _____
_____	0.75	_____	X 10.649	= _____	_____	0.75	_____	X 10.846	= _____
_____	1.00	_____	X 15.222	= _____	_____	1.00	_____	X 15.518	= _____
_____	1.50	_____	X 18.886	= _____	_____	1.50	_____	X 19.280	= _____
_____	2.00	_____	X 25.349	= _____	_____	2.00	_____	X 25.940	= _____
_____	3.00	_____	X 28.226	= _____	_____	3.00	_____	X 29.013	= _____
_____	4.00	_____	X 30.594	= _____	_____	4.00	_____	X 31.768	= _____
_____	6.00	_____	X 20.023	= _____	_____	6.00	_____	X 22.044	= _____
_____	8.00	_____	x 6.241	= _____	_____	8.00	_____	x 5.209	= _____
_____	10.00	_____	X 29.159	= _____	_____	10.00	_____	X 27.707	= _____
_____	12.00	_____	X 37.203	= _____	_____	12.00	_____	X 36.159	= _____
_____	13.00	_____	X 23.482	= _____	_____	13.00	_____	X 31.373	= _____
_____	13.50	_____	X 17.453	= _____	_____	14.00	_____	X 27.273	= _____
_____	14.00	_____	X 14.019	= _____	_____	14.50	_____	X 14.840	= _____
_____	14.25	_____	x 9.792	= _____	_____	14.75	_____	X 10.339	= _____
_____	14.50	_____	X 10.145	= _____	_____	15.00	_____	X 10.692	= _____
_____	14.75	_____	X 10.498	= _____	_____	15.25	_____	X 11.044	= _____
_____	15.00	_____	X 10.849	= _____	_____	15.50	_____	X 20.181	= _____
_____	15.25	_____	X 19.839	= _____	_____			TOTAL _____	
_____			TOTAL _____		_____			TOTAL _____	
_____			TOTAL _____	÷ 383.22 = MEAN VEL _____	_____			TOTAL _____	÷ 395.96 = MEAN VEL _____

PIPE ID = 16.50"      # OF DATA POINTS 21					PIPE ID = 16.75"      # OF DATA POINTS 21				
REF (RD) DISTANCE	SENSOR LOCATION	MEASURED VELOCITY (FPS)	WEIGHT CONSTANT	WEIGHTED VELOCITY	REF (RD) DISTANCE	SENSOR LOCATION	MEASURED VELOCITY (FPS)	WEIGHT CONSTANT	WEIGHTED VELOCITY
_____	0.00	_____	X 28.127 =	_____	_____	0.00	_____	X 28.569 =	_____
_____	0.25	_____	X 11.851 =	_____	_____	0.25	_____	X 12.047 =	_____
_____	0.50	_____	X 11.446 =	_____	_____	0.50	_____	X 11.643 =	_____
_____	0.75	_____	X 11.043 =	_____	_____	0.75	_____	X 11.240 =	_____
_____	1.00	_____	X 15.814 =	_____	_____	1.00	_____	X 16.109 =	_____
_____	1.50	_____	X 19.675 =	_____	_____	1.50	_____	X 20.069 =	_____
_____	2.00	_____	X 26.531 =	_____	_____	2.00	_____	X 27.123 =	_____
_____	3.00	_____	X 29.800 =	_____	_____	3.00	_____	X 30.588 =	_____
_____	4.00	_____	X 32.943 =	_____	_____	4.00	_____	X 34.118 =	_____
_____	6.00	_____	X 24.164 =	_____	_____	6.00	_____	X 26.382 =	_____
_____	8.00	_____	x 4.269 =	_____	_____	8.00	_____	x 3.421 =	_____
_____	10.00	_____	X 26.248 =	_____	_____	10.00	_____	X 24.782 =	_____
_____	12.00	_____	X 35.109 =	_____	_____	12.00	_____	X 34.052 =	_____
_____	13.00	_____	X 30.693 =	_____	_____	13.00	_____	X 30.009 =	_____
_____	14.00	_____	X 26.778 =	_____	_____	14.00	_____	X 26.278 =	_____
_____	14.50	_____	X 14.597 =	_____	_____	14.50	_____	X 19.319 =	_____
_____	14.75	_____	X 10.178 =	_____	_____	15.00	_____	X 15.420 =	_____
_____	15.00	_____	X 10.533 =	_____	_____	15.25	_____	X 10.727 =	_____
_____	15.25	_____	X 10.886 =	_____	_____	15.50	_____	X 11.081 =	_____
_____	15.50	_____	X 11.239 =	_____	_____	15.75	_____	X 11.434 =	_____
_____	15.75	_____	X 20.524 =	_____	_____	16.00	_____	X 20.866 =	_____
_____			TOTAL _____	_____	_____			TOTAL _____	_____
TOTAL _____ ÷ 408.92 = MEAN VEL _____					TOTAL _____ ÷ 422.10 = MEAN VEL _____				

16.50 - 16.75

17.00 - 17.25

PIPE ID = 17.00"      # OF DATA POINTS 22					PIPE ID = 17.25"      # OF DATA POINTS 20				
REF (RD) DISTANCE	SENSOR LOCATION	MEASURED VELOCITY (FPS)	WEIGHT CONSTANT	WEIGHTED VELOCITY	REF (RD) DISTANCE	SENSOR LOCATION	MEASURED VELOCITY (FPS)	WEIGHT CONSTANT	WEIGHTED VELOCITY
_____	0.00	_____	X 29.011	= _____	_____	0.00	_____	X 29.454	= _____
_____	0.25	_____	X 12.244	= _____	_____	0.25	_____	X 12.441	= _____
_____	0.50	_____	X 11.840	= _____	_____	0.50	_____	X 12.037	= _____
_____	0.75	_____	X 11.437	= _____	_____	0.75	_____	X 11.634	= _____
_____	1.00	_____	X 16.405	= _____	_____	1.00	_____	X 16.700	= _____
_____	1.50	_____	X 20.463	= _____	_____	1.50	_____	X 20.858	= _____
_____	2.00	_____	X 27.714	= _____	_____	2.00	_____	X 28.305	= _____
_____	3.00	_____	X 31.375	= _____	_____	3.00	_____	X 32.163	= _____
_____	4.00	_____	X 35.294	= _____	_____	4.00	_____	X 36.470	= _____
_____	6.00	_____	X 25.244	= _____	_____	6.00	_____	X 26.794	= _____
_____	8.00	_____	x 3.425	= _____	_____	8.00	_____	x 4.283	= _____
_____	10.00	_____	X 25.955	= _____	_____	10.00	_____	X 23.824	= _____
_____	12.00	_____	X 32.988	= _____	_____	12.00	_____	X 45.545	= _____
_____	13.00	_____	X 29.319	= _____	_____	14.00	_____	X 49.418	= _____
_____	14.00	_____	X 25.773	= _____	_____	15.00	_____	X 29.580	= _____
_____	14.50	_____	X 18.988	= _____	_____	15.50	_____	X 16.000	= _____
_____	15.00	_____	X 15.175	= _____	_____	15.75	_____	X 11.114	= _____
_____	15.25	_____	X 10.565	= _____	_____	16.00	_____	X 11.469	= _____
_____	15.50	_____	X 10.920	= _____	_____	16.25	_____	X 11.824	= _____
_____	15.75	_____	X 11.275	= _____	_____	16.50	_____	X 21.551	= _____
_____	16.00	_____	X 11.629	= _____	_____			TOTAL _____	
_____	16.25	_____	X 21.208	= _____				TOTAL _____ ÷ 449.11 = MEAN VEL _____	
_____			TOTAL _____						
			TOTAL _____ ÷ 435.50 = MEAN VEL _____						

PIPE ID = 17.50"      # OF DATA POINTS 21					PIPE ID = 17.75"      # OF DATA POINTS 21				
REF (RD) DISTANCE	SENSOR LOCATION	MEASURED VELOCITY (FPS)	WEIGHT CONSTANT	WEIGHTED VELOCITY	REF (RD) DISTANCE	SENSOR LOCATION	MEASURED VELOCITY (FPS)	WEIGHT CONSTANT	WEIGHTED VELOCITY
_____	0.00	_____	X 29.896	= _____	_____	0.00	_____	X 30.338	= _____
_____	0.25	_____	X 12.637	= _____	_____	0.25	_____	X 12.834	= _____
_____	0.50	_____	X 12.234	= _____	_____	0.50	_____	X 12.430	= _____
_____	0.75	_____	X 11.831	= _____	_____	0.75	_____	X 12.027	= _____
_____	1.00	_____	X 16.996	= _____	_____	1.00	_____	X 17.291	= _____
_____	1.50	_____	X 21.252	= _____	_____	1.50	_____	X 21.646	= _____
_____	2.00	_____	X 28.897	= _____	_____	2.00	_____	X 29.488	= _____
_____	3.00	_____	X 32.950	= _____	_____	3.00	_____	X 33.738	= _____
_____	4.00	_____	X 37.646	= _____	_____	4.00	_____	X 38.823	= _____
_____	6.00	_____	X 28.346	= _____	_____	6.00	_____	X 29.899	= _____
_____	8.00	_____	x 5.237	= _____	_____	8.00	_____	x 6.288	= _____
_____	10.00	_____	X 21.780	= _____	_____	10.00	_____	X 19.824	= _____
_____	12.00	_____	X 44.117	= _____	_____	12.00	_____	X 42.682	= _____
_____	14.00	_____	X 48.391	= _____	_____	14.00	_____	X 47.357	= _____
_____	15.00	_____	X 29.081	= _____	_____	15.00	_____	X 28.578	= _____
_____	15.50	_____	X 15.754	= _____	_____	15.50	_____	X 20.859	= _____
_____	15.75	_____	X 10.952	= _____	_____	16.00	_____	X 16.580	= _____
_____	16.00	_____	X 11.308	= _____	_____	16.25	_____	X 11.502	= _____
_____	16.25	_____	X 11.664	= _____	_____	16.50	_____	X 11.858	= _____
_____	16.50	_____	X 12.019	= _____	_____	16.75	_____	X 12.214	= _____
_____	16.75	_____	X 21.893	= _____	_____	17.00	_____	X 22.236	= _____
_____			TOTAL _____		_____			TOTAL _____	
TOTAL _____ ÷ 462.95 = MEAN VEL _____					TOTAL _____ ÷ 476.99 = MEAN VEL _____				

17.50 - 17.75

18.00 - 18.25

PIPE ID = 18.00"      # OF DATA POINTS 22					PIPE ID = 18.25"      # OF DATA POINTS 21				
REF (RD) DISTANCE	SENSOR LOCATION	MEASURED VELOCITY (FPS)	WEIGHT CONSTANT	WEIGHTED VELOCITY	REF (RD) DISTANCE	SENSOR LOCATION	MEASURED VELOCITY (FPS)	WEIGHT CONSTANT	WEIGHTED VELOCITY
_____	0.00	_____	X 30.781	= _____	_____	0.00	_____	X 31.223	= _____
_____	0.25	_____	X 13.031	= _____	_____	0.25	_____	X 13.227	= _____
_____	0.50	_____	X 12.627	= _____	_____	0.50	_____	X 12.824	= _____
_____	0.75	_____	X 12.224	= _____	_____	0.75	_____	X 12.421	= _____
_____	1.00	_____	X 17.587	= _____	_____	1.00	_____	X 17.882	= _____
_____	1.50	_____	X 22.040	= _____	_____	1.50	_____	X 22.435	= _____
_____	2.00	_____	X 30.079	= _____	_____	2.00	_____	X 30.670	= _____
_____	3.00	_____	X 34.525	= _____	_____	3.00	_____	X 35.313	= _____
_____	4.00	_____	X 40.001	= _____	_____	4.00	_____	X 41.178	= _____
_____	6.00	_____	X 31.454	= _____	_____	6.00	_____	X 33.010	= _____
_____	8.00	_____	x 7.435	= _____	_____	8.00	_____	x 8.680	= _____
_____	10.00	_____	X 17.957	= _____	_____	10.00	_____	X 16.180	= _____
_____	12.00	_____	X 41.239	= _____	_____	12.00	_____	X 39.791	= _____
_____	14.00	_____	X 46.315	= _____	_____	14.00	_____	X 45.268	= _____
_____	15.00	_____	X 28.070	= _____	_____	15.00	_____	X 37.488	= _____
_____	15.50	_____	X 20.526	= _____	_____	16.00	_____	X 31.892	= _____
_____	16.00	_____	X 16.333	= _____	_____	16.50	_____	X 17.161	= _____
_____	16.25	_____	X 11.339	= _____	_____	16.75	_____	X 11.891	= _____
_____	16.50	_____	X 11.697	= _____	_____	17.00	_____	X 12.248	= _____
_____	16.75	_____	X 12.053	= _____	_____	17.25	_____	X 12.604	= _____
_____	17.00	_____	X 12.409	= _____	_____	17.50	_____	X 22.921	= _____
_____	17.25	_____	X 22.578	= _____	_____			TOTAL _____	
			TOTAL _____					TOTAL _____	
TOTAL _____ ÷ 491.26 = MEAN VEL _____					TOTAL _____ ÷ 505.74 = MEAN VEL _____				

PIPE ID = 18.50"      # OF DATA POINTS 22					PIPE ID = 18.75"      # OF DATA POINTS 22				
REF (RD) DISTANCE	SENSOR LOCATION	MEASURED VELOCITY (FPS)	WEIGHT CONSTANT	WEIGHTED VELOCITY	REF (RD) DISTANCE	SENSOR LOCATION	MEASURED VELOCITY (FPS)	WEIGHT CONSTANT	WEIGHTED VELOCITY
_____	0.00	_____	X 31.665 =	_____	_____	0.00	_____	X 32.107 =	_____
_____	0.25	_____	X 13.424 =	_____	_____	0.25	_____	X 13.621 =	_____
_____	0.50	_____	X 13.021 =	_____	_____	0.50	_____	X 13.218 =	_____
_____	0.75	_____	X 12.618 =	_____	_____	0.75	_____	X 12.815 =	_____
_____	1.00	_____	X 18.178 =	_____	_____	1.00	_____	X 18.473 =	_____
_____	1.50	_____	X 22.829 =	_____	_____	1.50	_____	X 23.223 =	_____
_____	2.00	_____	X 31.261 =	_____	_____	2.00	_____	X 31.852 =	_____
_____	3.00	_____	X 36.101 =	_____	_____	3.00	_____	X 36.888 =	_____
_____	4.00	_____	X 42.356 =	_____	_____	4.00	_____	X 43.534 =	_____
_____	6.00	_____	X 34.566 =	_____	_____	6.00	_____	X 36.124 =	_____
_____	8.00	_____	X 10.022 =	_____	_____	8.00	_____	X 11.461 =	_____
_____	10.00	_____	X 14.493 =	_____	_____	10.00	_____	X 12.897 =	_____
_____	12.00	_____	X 38.337 =	_____	_____	12.00	_____	X 36.877 =	_____
_____	14.00	_____	X 44.214 =	_____	_____	14.00	_____	X 43.155 =	_____
_____	15.00	_____	X 36.803 =	_____	_____	15.00	_____	X 36.113 =	_____
_____	16.00	_____	X 31.389 =	_____	_____	16.00	_____	X 30.883 =	_____
_____	16.50	_____	X 16.913 =	_____	_____	16.50	_____	X 22.403 =	_____
_____	16.75	_____	X 11.727 =	_____	_____	17.00	_____	X 17.742 =	_____
_____	17.00	_____	X 12.085 =	_____	_____	17.25	_____	X 12.279 =	_____
_____	17.25	_____	X 12.442 =	_____	_____	17.50	_____	X 12.637 =	_____
_____	17.50	_____	X 12.799 =	_____	_____	17.75	_____	X 12.994 =	_____
_____	17.75	_____	X 23.263 =	_____	_____	18.00	_____	X 23.606 =	_____
_____			TOTAL _____		_____			TOTAL _____	
TOTAL _____ ÷ 520.44 = MEAN VEL _____					TOTAL _____ ÷ 535.36 = MEAN VEL _____				

18.50 - 18.75





PIPE ID = 19.50"      # OF DATA POINTS 22					PIPE ID = 19.75"      # OF DATA POINTS 22				
REF (RD) DISTANCE	SENSOR LOCATION	MEASURED VELOCITY (FPS)	WEIGHT CONSTANT	WEIGHTED VELOCITY	REF (RD) DISTANCE	SENSOR LOCATION	MEASURED VELOCITY (FPS)	WEIGHT CONSTANT	WEIGHTED VELOCITY
_____	0.00	_____	X 33.434	= _____	_____	0.00	_____	X 33.876	= _____
_____	0.25	_____	X 14.211	= _____	_____	0.25	_____	X 14.407	= _____
_____	0.50	_____	X 13.808	= _____	_____	0.50	_____	X 14.005	= _____
_____	0.75	_____	X 13.406	= _____	_____	0.75	_____	X 13.602	= _____
_____	1.00	_____	X 19.359	= _____	_____	1.00	_____	X 19.655	= _____
_____	1.50	_____	X 24.405	= _____	_____	1.50	_____	X 24.799	= _____
_____	2.00	_____	X 33.626	= _____	_____	2.00	_____	X 34.217	= _____
_____	3.00	_____	X 39.252	= _____	_____	3.00	_____	X 40.040	= _____
_____	4.00	_____	X 47.069	= _____	_____	4.00	_____	X 48.248	= _____
_____	6.00	_____	X 40.803	= _____	_____	6.00	_____	X 42.364	= _____
_____	8.00	_____	X 16.362	= _____	_____	8.00	_____	X 18.191	= _____
_____	10.00	_____	X 8.657	= _____	_____	10.00	_____	X 7.428	= _____
_____	12.00	_____	X 32.468	= _____	_____	12.00	_____	X 30.989	= _____
_____	14.00	_____	X 56.261	= _____	_____	14.00	_____	X 54.825	= _____
_____	16.00	_____	X 57.568	= _____	_____	16.00	_____	X 56.526	= _____
_____	17.00	_____	X 33.702	= _____	_____	17.00	_____	X 33.193	= _____
_____	17.50	_____	X 18.074	= _____	_____	17.50	_____	X 23.949	= _____
_____	17.75	_____	X 12.503	= _____	_____	18.00	_____	X 18.906	= _____
_____	18.00	_____	X 12.862	= _____	_____	18.25	_____	X 13.057	= _____
_____	18.25	_____	X 13.221	= _____	_____	18.50	_____	X 13.416	= _____
_____	18.50	_____	X 13.580	= _____	_____	18.75	_____	X 13.775	= _____
_____	18.75	_____	X 24.634	= _____	_____	19.00	_____	X 24.976	= _____
_____			TOTAL _____		_____			TOTAL _____	
TOTAL _____ ÷ 581.39 = MEAN VEL _____					TOTAL _____ ÷ 597.16 = MEAN VEL _____				

19.50 - 19.75

20.00 - 20.25

PIPE ID = 20.00"      # OF DATA POINTS 23					PIPE ID = 20.25"      # OF DATA POINTS 22				
REF (RD) DISTANCE	SENSOR LOCATION	MEASURED VELOCITY (FPS)	WEIGHT CONSTANT	WEIGHTED VELOCITY	REF (RD) DISTANCE	SENSOR LOCATION	MEASURED VELOCITY (FPS)	WEIGHT CONSTANT	WEIGHTED VELOCITY
_____	0.00	_____	X 34.318	= _____	_____	0.00	_____	X 34.760	= _____
_____	0.25	_____	X 14.604	= _____	_____	0.25	_____	X 14.801	= _____
_____	0.50	_____	X 14.201	= _____	_____	0.50	_____	X 14.398	= _____
_____	0.75	_____	X 13.799	= _____	_____	0.75	_____	X 13.996	= _____
_____	1.00	_____	X 19.950	= _____	_____	1.00	_____	X 20.245	= _____
_____	1.50	_____	X 25.193	= _____	_____	1.50	_____	X 25.587	= _____
_____	2.00	_____	X 34.808	= _____	_____	2.00	_____	X 35.399	= _____
_____	3.00	_____	X 40.827	= _____	_____	3.00	_____	X 41.615	= _____
_____	4.00	_____	X 49.427	= _____	_____	4.00	_____	X 50.606	= _____
_____	6.00	_____	X 43.926	= _____	_____	6.00	_____	X 45.489	= _____
_____	8.00	_____	X 20.118	= _____	_____	8.00	_____	X 22.142	= _____
_____	10.00	_____	x 6.292	= _____	_____	10.00	_____	x 5.250	= _____
_____	12.00	_____	X 29.506	= _____	_____	12.00	_____	X 28.019	= _____
_____	14.00	_____	X 53.384	= _____	_____	14.00	_____	X 51.937	= _____
_____	16.00	_____	X 55.479	= _____	_____	16.00	_____	X 54.427	= _____
_____	17.00	_____	X 32.680	= _____	_____	17.00	_____	X 43.632	= _____
_____	17.50	_____	X 23.612	= _____	_____	18.00	_____	X 36.527	= _____
_____	18.00	_____	X 18.656	= _____	_____	18.50	_____	X 19.488	= _____
_____	18.25	_____	X 12.891	= _____	_____	18.75	_____	X 13.446	= _____
_____	18.50	_____	X 13.251	= _____	_____	19.00	_____	X 13.806	= _____
_____	18.75	_____	X 13.611	= _____	_____	19.25	_____	X 14.166	= _____
_____	19.00	_____	X 13.971	= _____	_____	19.50	_____	X 25.662	= _____
_____	19.25	_____	X 25.319	= _____	_____			TOTAL	_____
_____			TOTAL	_____	_____			TOTAL	_____
			TOTAL _____	÷ 613.15 = MEAN VEL _____				TOTAL _____	÷ 629.34 = MEAN VEL _____

PIPE ID = 20.50" # OF DATA POINTS 23					PIPE ID = 20.75" # OF DATA POINTS 23				
REF (RD) DISTANCE	SENSOR LOCATION	MEASURED VELOCITY (FPS)	WEIGHT CONSTANT	WEIGHTED VELOCITY	REF (RD) DISTANCE	SENSOR LOCATION	MEASURED VELOCITY (FPS)	WEIGHT CONSTANT	WEIGHTED VELOCITY
_____	0.00	_____	X 35.202	= _____	_____	0.00	_____	X 35.645	= _____
_____	0.25	_____	X 14.997	= _____	_____	0.25	_____	X 15.194	= _____
_____	0.50	_____	X 14.595	= _____	_____	0.50	_____	X 14.792	= _____
_____	0.75	_____	X 14.193	= _____	_____	0.75	_____	X 14.390	= _____
_____	1.00	_____	X 20.541	= _____	_____	1.00	_____	X 20.836	= _____
_____	1.50	_____	X 25.981	= _____	_____	1.50	_____	X 26.375	= _____
_____	2.00	_____	X 35.990	= _____	_____	2.00	_____	X 36.581	= _____
_____	3.00	_____	X 42.403	= _____	_____	3.00	_____	X 43.191	= _____
_____	4.00	_____	X 51.785	= _____	_____	4.00	_____	X 52.964	= _____
_____	6.00	_____	X 47.052	= _____	_____	6.00	_____	X 48.616	= _____
_____	8.00	_____	X 24.265	= _____	_____	8.00	_____	X 26.485	= _____
_____	10.00	_____	X 4.301	= _____	_____	10.00	_____	X 3.445	= _____
_____	12.00	_____	X 26.529	= _____	_____	12.00	_____	X 25.034	= _____
_____	14.00	_____	X 50.484	= _____	_____	14.00	_____	X 49.027	= _____
_____	16.00	_____	X 53.369	= _____	_____	16.00	_____	X 52.306	= _____
_____	17.00	_____	X 42.941	= _____	_____	17.00	_____	X 42.247	= _____
_____	18.00	_____	X 36.019	= _____	_____	18.00	_____	X 35.507	= _____
_____	18.50	_____	X 19.237	= _____	_____	18.50	_____	X 25.498	= _____
_____	18.75	_____	X 13.279	= _____	_____	19.00	_____	X 20.071	= _____
_____	19.00	_____	X 13.641	= _____	_____	19.25	_____	X 13.835	= _____
_____	19.25	_____	X 14.001	= _____	_____	19.50	_____	X 14.196	= _____
_____	19.50	_____	X 14.361	= _____	_____	19.75	_____	X 14.557	= _____
_____	19.75	_____	X 26.004	= _____	_____	20.00	_____	X 26.347	= _____
_____			TOTAL _____		_____			TOTAL _____	
TOTAL _____ ÷ 645.75 = MEAN VEL _____					TOTAL _____ ÷ 662.37 = MEAN VEL _____				

20.50 - 20.75



PIPE ID = 21.50" # OF DATA POINTS 23					PIPE ID = 21.75" # OF DATA POINTS 23				
REF (RD) DISTANCE	SENSOR LOCATION	MEASURED VELOCITY (FPS)	WEIGHT CONSTANT	WEIGHTED VELOCITY	REF (RD) DISTANCE	SENSOR LOCATION	MEASURED VELOCITY (FPS)	WEIGHT CONSTANT	WEIGHTED VELOCITY
_____	0.00	_____	X 36.971	= _____	_____	0.00	_____	X 37.413	= _____
_____	0.25	_____	X 15.784	= _____	_____	0.25	_____	X 15.980	= _____
_____	0.50	_____	X 15.382	= _____	_____	0.50	_____	X 15.578	= _____
_____	0.75	_____	X 14.980	= _____	_____	0.75	_____	X 15.177	= _____
_____	1.00	_____	X 21.722	= _____	_____	1.00	_____	X 22.017	= _____
_____	1.50	_____	X 27.557	= _____	_____	1.50	_____	X 27.950	= _____
_____	2.00	_____	X 38.354	= _____	_____	2.00	_____	X 38.944	= _____
_____	3.00	_____	X 45.554	= _____	_____	3.00	_____	X 46.342	= _____
_____	4.00	_____	X 56.503	= _____	_____	4.00	_____	X 57.683	= _____
_____	6.00	_____	X 53.311	= _____	_____	6.00	_____	X 54.877	= _____
_____	.00	_____	X 28.437	= _____	_____	8.00	_____	X 29.989	= _____
_____	10.00	_____	x 5.268	= _____	_____	10.00	_____	x 6.323	= _____
_____	12.00	_____	X 21.970	= _____	_____	12.00	_____	X 19.989	= _____
_____	14.00	_____	X 44.627	= _____	_____	14.00	_____	X 43.152	= _____
_____	16.00	_____	X 68.463	= _____	_____	16.00	_____	X 67.026	= _____
_____	18.00	_____	X 66.784	= _____	_____	18.00	_____	X 65.736	= _____
_____	19.00	_____	X 38.339	= _____	_____	19.00	_____	X 37.824	= _____
_____	19.50	_____	X 20.401	= _____	_____	19.50	_____	X 27.048	= _____
_____	19.75	_____	X 14.057	= _____	_____	20.00	_____	X 21.237	= _____
_____	20.00	_____	X 14.419	= _____	_____	20.25	_____	X 14.614	= _____
_____	20.25	_____	X 14.781	= _____	_____	20.50	_____	X 14.977	= _____
_____	20.50	_____	X 15.143	= _____	_____	20.75	_____	X 15.338	= _____
_____	20.75	_____	X 27.376	= _____	_____	21.00	_____	X 27.719	= _____
_____			TOTAL _____		_____			TOTAL _____	
TOTAL _____ ÷ 713.47 = MEAN VEL _____					TOTAL _____ ÷ 730.92 = MEAN VEL _____				

21.50 - 21.75

22.00 - 22.25

PIPE ID = 22.00"      # OF DATA POINTS 24					PIPE ID = 22.25"      # OF DATA POINTS 23				
REF (RD) DISTANCE	SENSOR LOCATION	MEASURED VELOCITY (FPS)	WEIGHT CONSTANT	WEIGHTED VELOCITY	REF (RD) DISTANCE	SENSOR LOCATION	MEASURED VELOCITY (FPS)	WEIGHT CONSTANT	WEIGHTED VELOCITY
_____	0.00	_____	X 37.855	= _____	_____	0.00	_____	X 38.297	= _____
_____	0.25	_____	X 16.177	= _____	_____	0.25	_____	X 16.373	= _____
_____	0.50	_____	X 15.775	= _____	_____	0.50	_____	X 15.972	= _____
_____	0.75	_____	X 15.374	= _____	_____	0.75	_____	X 15.570	= _____
_____	1.00	_____	X 22.312	= _____	_____	1.00	_____	X 22.607	= _____
_____	1.50	_____	X 28.344	= _____	_____	1.50	_____	X 28.738	= _____
_____	2.00	_____	X 39.535	= _____	_____	2.00	_____	X 40.126	= _____
_____	3.00	_____	X 47.130	= _____	_____	3.00	_____	X 47.918	= _____
_____	4.00	_____	X 58.863	= _____	_____	4.00	_____	X 60.043	= _____
_____	6.00	_____	X 56.443	= _____	_____	6.00	_____	X 58.010	= _____
_____	8.00	_____	X 31.542	= _____	_____	8.00	_____	X 33.096	= _____
_____	10.00	_____	x 7.475	= _____	_____	10.00	_____	x 8.724	= _____
_____	12.00	_____	X 18.099	= _____	_____	12.00	_____	X 16.302	= _____
_____	14.00	_____	X 41.673	= _____	_____	14.00	_____	X 40.191	= _____
_____	16.00	_____	X 65.583	= _____	_____	16.00	_____	X 64.135	= _____
_____	18.00	_____	X 64.683	= _____	_____	18.00	_____	X 63.626	= _____
_____	19.00	_____	X 37.307	= _____	_____	19.00	_____	X 49.799	= _____
_____	19.50	_____	X 26.707	= _____	_____	20.00	_____	X 41.176	= _____
_____	20.00	_____	X 20.983	= _____	_____	20.50	_____	X 21.821	= _____
_____	20.25	_____	X 14.446	= _____	_____	20.75	_____	X 15.004	= _____
_____	20.50	_____	X 14.809	= _____	_____	21.00	_____	X 15.367	= _____
_____	20.75	_____	X 15.172	= _____	_____	21.25	_____	X 15.729	= _____
_____	21.00	_____	X 15.534	= _____	_____	21.50	_____	X 28.404	= _____
_____	21.25	_____	X 28.061	= _____	_____			TOTAL _____	
_____			TOTAL _____		_____			TOTAL _____	
			TOTAL _____ ÷ 748.58 = MEAN VEL _____					TOTAL _____ ÷ 766.44 = MEAN VEL _____	

PIPE ID = 22.50"      # OF DATA POINTS 24					PIPE ID = 22.75"      # OF DATA POINTS 24				
REF (RD) DISTANCE	SENSOR LOCATION	MEASURED VELOCITY (FPS)	WEIGHT CONSTANT	WEIGHTED VELOCITY	REF (RD) DISTANCE	SENSOR LOCATION	MEASURED VELOCITY (FPS)	WEIGHT CONSTANT	WEIGHTED VELOCITY
_____	0.00	_____	X 38.739	= _____	_____	0.00	_____	X 39.181	= _____
_____	0.25	_____	X 16.570	= _____	_____	0.25	_____	X 16.767	= _____
_____	0.50	_____	X 16.168	= _____	_____	0.50	_____	X 16.365	= _____
_____	0.75	_____	X 15.767	= _____	_____	0.75	_____	X 15.964	= _____
_____	1.00	_____	X 22.902	= _____	_____	1.00	_____	X 23.198	= _____
_____	1.50	_____	X 29.132	= _____	_____	1.50	_____	X 29.526	= _____
_____	2.00	_____	X 40.717	= _____	_____	2.00	_____	X 41.308	= _____
_____	3.00	_____	X 48.705	= _____	_____	3.00	_____	X 49.493	= _____
_____	4.00	_____	X 61.223	= _____	_____	4.00	_____	X 62.403	= _____
_____	6.00	_____	X 59.577	= _____	_____	6.00	_____	X 61.145	= _____
_____	8.00	_____	X 34.651	= _____	_____	8.00	_____	X 36.207	= _____
_____	10.00	_____	X 10.070	= _____	_____	10.00	_____	X 11.513	= _____
_____	12.00	_____	X 14.597	= _____	_____	12.00	_____	X 12.985	= _____
_____	14.00	_____	X 38.705	= _____	_____	14.00	_____	X 37.215	= _____
_____	16.00	_____	X 62.683	= _____	_____	16.00	_____	X 61.226	= _____
_____	18.00	_____	X 62.563	= _____	_____	18.00	_____	X 61.496	= _____
_____	19.00	_____	X 49.103	= _____	_____	19.00	_____	X 48.403	= _____
_____	20.00	_____	X 40.662	= _____	_____	20.00	_____	X 40.145	= _____
_____	20.50	_____	X 21.566	= _____	_____	20.50	_____	X 28.600	= _____
_____	20.75	_____	X 14.835	= _____	_____	21.00	_____	X 22.404	= _____
_____	21.00	_____	X 15.199	= _____	_____	21.25	_____	X 15.394	= _____
_____	21.25	_____	X 15.562	= _____	_____	21.50	_____	X 15.757	= _____
_____	21.50	_____	X 15.925	= _____	_____	21.75	_____	X 16.121	= _____
_____	21.75	_____	X 28.747	= _____	_____	22.00	_____	X 29.090	= _____
_____			TOTAL _____		_____			TOTAL _____	
TOTAL _____ ÷ 784.50 = MEAN VEL _____					TOTAL _____ ÷ 802.76 = MEAN VEL _____				

22.50 - 22.75



23.00 - 23.25

PIPE ID = 23.00"      # OF DATA POINTS 25					PIPE ID = 23.25"      # OF DATA POINTS 23				
REF (RD) DISTANCE	SENSOR LOCATION	MEASURED VELOCITY (FPS)	WEIGHT CONSTANT	WEIGHTED VELOCITY	REF (RD) DISTANCE	SENSOR LOCATION	MEASURED VELOCITY (FPS)	WEIGHT CONSTANT	WEIGHTED VELOCITY
_____	0.00	_____	X 39.624	= _____	_____	0.00	_____	X 40.066	= _____
_____	0.25	_____	X 16.963	= _____	_____	0.25	_____	X 17.160	= _____
_____	0.50	_____	X 16.562	= _____	_____	0.50	_____	X 16.758	= _____
_____	0.75	_____	X 16.160	= _____	_____	0.75	_____	X 16.357	= _____
_____	1.00	_____	X 23.493	= _____	_____	1.00	_____	X 23.788	= _____
_____	1.50	_____	X 29.919	= _____	_____	1.50	_____	X 30.313	= _____
_____	2.00	_____	X 41.898	= _____	_____	2.00	_____	X 42.489	= _____
_____	3.00	_____	X 50.281	= _____	_____	3.00	_____	X 51.069	= _____
_____	4.00	_____	X 63.583	= _____	_____	4.00	_____	X 64.764	= _____
_____	6.00	_____	X 62.713	= _____	_____	6.00	_____	X 64.281	= _____
_____	8.00	_____	X 37.764	= _____	_____	8.00	_____	X 39.321	= _____
_____	10.00	_____	X 13.053	= _____	_____	10.00	_____	X 14.691	= _____
_____	12.00	_____	X 11.466	= _____	_____	12.00	_____	X 10.040	= _____
_____	14.00	_____	X 35.723	= _____	_____	14.00	_____	X 34.227	= _____
_____	16.00	_____	X 59.764	= _____	_____	16.00	_____	X 58.299	= _____
_____	18.00	_____	X 60.426	= _____	_____	18.00	_____	X 82.149	= _____
_____	19.00	_____	X 47.701	= _____	_____	20.00	_____	X 77.082	= _____
_____	20.00	_____	X 39.626	= _____	_____	21.00	_____	X 43.504	= _____
_____	20.50	_____	X 28.257	= _____	_____	21.50	_____	X 22.988	= _____
_____	21.00	_____	X 22.149	= _____	_____	21.75	_____	X 15.784	= _____
_____	21.25	_____	X 15.224	= _____	_____	22.00	_____	X 16.148	= _____
_____	21.50	_____	X 15.589	= _____	_____	22.25	_____	X 16.512	= _____
_____	21.75	_____	X 15.953	= _____	_____	22.50	_____	X 29.776	= _____
_____	22.00	_____	X 16.316	= _____	_____			TOTAL	_____
_____	22.25	_____	X 29.433	= _____	_____			TOTAL	_____
_____			TOTAL	_____	_____			TOTAL	_____
			TOTAL _____	÷ 821.23 = MEAN VEL _____				TOTAL _____	÷ 839.89 = MEAN VEL _____

PIPE ID = 23.50"      # OF DATA POINTS 24					PIPE ID = 23.75"      # OF DATA POINTS 24				
REF (RD) DISTANCE	SENSOR LOCATION	MEASURED VELOCITY (FPS)	WEIGHT CONSTANT	WEIGHTED VELOCITY	REF (RD) DISTANCE	SENSOR LOCATION	MEASURED VELOCITY (FPS)	WEIGHT CONSTANT	WEIGHTED VELOCITY
_____	0.00	_____	X 40.508	= _____	_____	0.00	_____	X 40.950	= _____
_____	0.25	_____	X 17.356	= _____	_____	0.25	_____	X 17.553	= _____
_____	0.50	_____	X 16.955	= _____	_____	0.50	_____	X 17.152	= _____
_____	0.75	_____	X 16.554	= _____	_____	0.75	_____	X 16.751	= _____
_____	1.00	_____	X 24.083	= _____	_____	1.00	_____	X 24.378	= _____
_____	1.50	_____	X 30.707	= _____	_____	1.50	_____	X 31.101	= _____
_____	2.00	_____	X 43.080	= _____	_____	2.00	_____	X 43.671	= _____
_____	3.00	_____	X 51.856	= _____	_____	3.00	_____	X 52.644	= _____
_____	4.00	_____	X 65.944	= _____	_____	4.00	_____	X 67.124	= _____
_____	6.00	_____	X 65.850	= _____	_____	6.00	_____	X 67.419	= _____
_____	8.00	_____	X 40.879	= _____	_____	8.00	_____	X 42.438	= _____
_____	10.00	_____	X 16.426	= _____	_____	10.00	_____	X 18.259	= _____
_____	12.00	_____	x 8.708	= _____	_____	12.00	_____	x 7.470	= _____
_____	14.00	_____	X 32.728	= _____	_____	14.00	_____	X 31.227	= _____
_____	16.00	_____	X 56.830	= _____	_____	16.00	_____	X 55.356	= _____
_____	18.00	_____	X 80.714	= _____	_____	18.00	_____	X 79.273	= _____
_____	20.00	_____	X 76.032	= _____	_____	20.00	_____	X 74.978	= _____
_____	21.00	_____	X 42.988	= _____	_____	21.00	_____	X 42.469	= _____
_____	21.50	_____	X 22.732	= _____	_____	21.50	_____	X 30.154	= _____
_____	21.75	_____	X 15.614	= _____	_____	22.00	_____	X 23.573	= _____
_____	22.00	_____	X 15.979	= _____	_____	22.25	_____	X 16.174	= _____
_____	22.25	_____	X 16.343	= _____	_____	22.50	_____	X 16.539	= _____
_____	22.50	_____	X 16.707	= _____	_____	22.75	_____	X 16.903	= _____
_____	22.75	_____	X 30.119	= _____	_____	23.00	_____	X 30.462	= _____
_____			TOTAL _____		_____			TOTAL _____	
TOTAL _____ ÷ 858.75 = MEAN VEL _____					TOTAL _____ ÷ 877.81 = MEAN VEL _____				

23.50 - 23.75

24.00 - 24.25

PIPE ID = 24.00"      # OF DATA POINTS 25					PIPE ID = 24.25"      # OF DATA POINTS 24				
REF (RD) DISTANCE	SENSOR LOCATION	MEASURED VELOCITY (FPS)	WEIGHT CONSTANT	WEIGHTED VELOCITY	REF (RD) DISTANCE	SENSOR LOCATION	MEASURED VELOCITY (FPS)	WEIGHT CONSTANT	WEIGHTED VELOCITY
_____	0.00	_____	X 41.392	= _____	_____	0.00	_____	x 41.834	= _____
_____	0.25	_____	X 17.749	= _____	_____	0.25	_____	x 17.946	= _____
_____	0.50	_____	X 17.348	= _____	_____	0.50	_____	x 17.545	= _____
_____	0.75	_____	X 16.947	= _____	_____	0.75	_____	x 17.144	= _____
_____	1.00	_____	X 24.673	= _____	_____	1.00	_____	x 24.969	= _____
_____	1.50	_____	X 31.494	= _____	_____	1.50	_____	x 31.888	= _____
_____	2.00	_____	X 44.261	= _____	_____	2.00	_____	x 44.852	= _____
_____	3.00	_____	X 53.432	= _____	_____	3.00	_____	x 54.220	= _____
_____	4.00	_____	X 68.305	= _____	_____	4.00	_____	x 69.485	= _____
_____	6.00	_____	X 68.988	= _____	_____	6.00	_____	x 70.557	= _____
_____	8.00	_____	x 43.998	= _____	_____	8.00	_____	x 45.558	= _____
_____	10.00	_____	x 20.189	= _____	_____	10.00	_____	x 22.216	= _____
_____	12.00	_____	x 6.326	= _____	_____	12.00	_____	x 5.277	= _____
_____	14.00	_____	x 29.723	= _____	_____	14.00	_____	x 28.216	= _____
_____	16.00	_____	x 53.880	= _____	_____	16.00	_____	x 52.399	= _____
_____	18.00	_____	x 77.828	= _____	_____	18.00	_____	x 76.379	= _____
_____	20.00	_____	x 73.919	= _____	_____	20.00	_____	x 72.856	= _____
_____	21.00	_____	x 41.947	= _____	_____	21.00	_____	x 55.982	= _____
_____	21.50	_____	x 29.809	= _____	_____	22.00	_____	x 45.834	= _____
_____	22.00	_____	x 23.316	= _____	_____	22.50	_____	x 24.157	= _____
_____	22.25	_____	x 16.003	= _____	_____	22.75	_____	x 16.564	= _____
_____	22.50	_____	x 16.369	= _____	_____	23.00	_____	x 16.929	= _____
_____	22.75	_____	x 16.734	= _____	_____	23.25	_____	x 17.294	= _____
_____	23.00	_____	x 17.099	= _____	_____	23.50	_____	x 31.148	= _____
_____	23.25	_____	x 30.805	= _____	_____			TOTAL _____	
_____			TOTAL _____		_____			TOTAL _____	
TOTAL _____ ÷ 897.06 = MEAN VEL _____					TOTAL _____ ÷ 916.51 = MEAN VEL _____				

PIPE ID = 24.50" # OF DATA POINTS 25					PIPE ID = 24.75" # OF DATA POINTS 25				
REF (RD) DISTANCE	SENSOR LOCATION	MEASURED VELOCITY (FPS)	WEIGHT CONSTANT	WEIGHTED VELOCITY	REF (RD) DISTANCE	SENSOR LOCATION	MEASURED VELOCITY (FPS)	WEIGHT CONSTANT	WEIGHTED VELOCITY
_____	0.00	_____	x 42.276	= _____	_____	0.00	_____	x 42.718	= _____
_____	0.25	_____	x 18.142	= _____	_____	0.25	_____	x 18.339	= _____
_____	0.50	_____	x 17.741	= _____	_____	0.50	_____	x 17.938	= _____
_____	0.75	_____	x 17.341	= _____	_____	0.75	_____	x 17.537	= _____
_____	1.00	_____	x 25.264	= _____	_____	1.00	_____	x 25.559	= _____
_____	1.50	_____	x 32.282	= _____	_____	1.50	_____	x 32.675	= _____
_____	2.00	_____	x 45.442	= _____	_____	2.00	_____	x 46.033	= _____
_____	3.00	_____	x 55.007	= _____	_____	3.00	_____	x 55.795	= _____
_____	4.00	_____	x 70.665	= _____	_____	4.00	_____	x 71.846	= _____
_____	6.00	_____	x 72.127	= _____	_____	6.00	_____	x 73.697	= _____
_____	8.00	_____	x 47.119	= _____	_____	8.00	_____	x 48.680	= _____
_____	10.00	_____	x 24.341	= _____	_____	10.00	_____	x 26.564	= _____
_____	12.00	_____	x 4.322	= _____	_____	12.00	_____	x 3.462	= _____
_____	14.00	_____	x 26.707	= _____	_____	14.00	_____	x 25.196	= _____
_____	16.00	_____	x 50.916	= _____	_____	16.00	_____	x 49.429	= _____
_____	18.00	_____	x 74.925	= _____	_____	18.00	_____	x 73.467	= _____
_____	20.00	_____	x 71.789	= _____	_____	20.00	_____	x 70.718	= _____
_____	21.00	_____	x 55.282	= _____	_____	21.00	_____	x 54.578	= _____
_____	22.00	_____	x 45.316	= _____	_____	22.00	_____	x 44.794	= _____
_____	22.50	_____	x 23.900	= _____	_____	22.50	_____	x 31.709	= _____
_____	22.75	_____	x 16.393	= _____	_____	23.00	_____	x 24.741	= _____
_____	23.00	_____	x 16.759	= _____	_____	23.25	_____	x 16.954	= _____
_____	23.25	_____	x 17.125	= _____	_____	23.50	_____	x 17.320	= _____
_____	23.50	_____	x 17.490	= _____	_____	23.75	_____	x 17.685	= _____
_____	23.75	_____	x 31.491	= _____	_____	24.00	_____	x 31.834	= _____
_____			TOTAL	_____	_____			TOTAL	_____
TOTAL _____ ÷ 936.15 = MEAN VEL _____					TOTAL _____ ÷ 955.98 = MEAN VEL _____				

24.50 - 24.75

25.00 - 25.25

PIPE ID = 25.00"      # OF DATA POINTS 26					PIPE ID = 25.25"      # OF DATA POINTS 24				
REF (RD) DISTANCE	SENSOR LOCATION	MEASURED VELOCITY (FPS)	WEIGHT CONSTANT	WEIGHTED VELOCITY	REF (RD) DISTANCE	SENSOR LOCATION	MEASURED VELOCITY (FPS)	WEIGHT CONSTANT	WEIGHTED VELOCITY
_____	0.00	_____	x 43.160	= _____	_____	0.00	_____	x 43.602	= _____
_____	0.25	_____	x 18.536	= _____	_____	0.25	_____	x 18.732	= _____
_____	0.50	_____	x 18.135	= _____	_____	0.50	_____	x 18.331	= _____
_____	0.75	_____	x 17.734	= _____	_____	0.75	_____	x 17.931	= _____
_____	1.00	_____	x 25.854	= _____	_____	1.00	_____	x 26.149	= _____
_____	1.50	_____	x 33.069	= _____	_____	1.50	_____	x 33.463	= _____
_____	2.00	_____	x 46.624	= _____	_____	2.00	_____	x 47.214	= _____
_____	3.00	_____	x 56.583	= _____	_____	3.00	_____	x 57.370	= _____
_____	4.00	_____	x 73.026	= _____	_____	4.00	_____	x 74.207	= _____
_____	6.00	_____	x 75.267	= _____	_____	6.00	_____	x 76.837	= _____
_____	8.00	_____	x 50.242	= _____	_____	8.00	_____	x 51.804	= _____
_____	10.00	_____	x 25.408	= _____	_____	10.00	_____	x 26.959	= _____
_____	12.00	_____	x 3.463	= _____	_____	12.00	_____	x 4.328	= _____
_____	14.00	_____	x 26.368	= _____	_____	14.00	_____	x 24.185	= _____
_____	16.00	_____	x 47.940	= _____	_____	16.00	_____	x 46.447	= _____
_____	18.00	_____	x 72.005	= _____	_____	18.00	_____	x 70.540	= _____
_____	20.00	_____	x 69.644	= _____	_____	20.00	_____	x 94.444	= _____
_____	21.00	_____	x 53.872	= _____	_____	22.00	_____	x 86.362	= _____
_____	22.00	_____	x 44.271	= _____	_____	23.00	_____	x 48.167	= _____
_____	22.50	_____	x 31.363	= _____	_____	23.50	_____	x 25.326	= _____
_____	23.00	_____	x 24.483	= _____	_____	23.75	_____	x 17.345	= _____
_____	23.25	_____	x 16.783	= _____	_____	24.00	_____	x 17.711	= _____
_____	23.50	_____	x 17.149	= _____	_____	24.25	_____	x 18.077	= _____
_____	23.75	_____	x 17.515	= _____	_____	24.50	_____	x 32.520	= _____
_____	24.00	_____	x 17.881	= _____	_____			TOTAL _____	
_____	24.25	_____	x 32.177	= _____				TOTAL _____	
_____			TOTAL _____					TOTAL _____	
			TOTAL _____	÷ 976.00 = MEAN VEL _____				TOTAL _____	÷ 996.21 = MEAN VEL _____

PIPE ID = 25.50"      # OF DATA POINTS 25					PIPE ID = 25.75"      # OF DATA POINTS 25				
REF (RD) DISTANCE	SENSOR LOCATION	MEASURED VELOCITY (FPS)	WEIGHT CONSTANT	WEIGHTED VELOCITY	REF (RD) DISTANCE	SENSOR LOCATION	MEASURED VELOCITY (FPS)	WEIGHT CONSTANT	WEIGHTED VELOCITY
_____	0.00	_____	x 44.044	= _____	_____	0.00	_____	x 44.486	= _____
_____	0.25	_____	x 18.929	= _____	_____	0.25	_____	x 19.125	= _____
_____	0.50	_____	x 18.528	= _____	_____	0.50	_____	x 18.724	= _____
_____	0.75	_____	x 18.127	= _____	_____	0.75	_____	x 18.324	= _____
_____	1.00	_____	x 26.444	= _____	_____	1.00	_____	x 26.739	= _____
_____	1.50	_____	x 33.856	= _____	_____	1.50	_____	x 34.250	= _____
_____	2.00	_____	x 47.805	= _____	_____	2.00	_____	x 48.395	= _____
_____	3.00	_____	x 58.158	= _____	_____	3.00	_____	x 58.945	= _____
_____	4.00	_____	x 75.388	= _____	_____	4.00	_____	x 76.568	= _____
_____	6.00	_____	x 78.408	= _____	_____	6.00	_____	x 79.979	= _____
_____	8.00	_____	x 53.367	= _____	_____	8.00	_____	x 54.930	= _____
_____	10.00	_____	x 28.510	= _____	_____	10.00	_____	x 30.063	= _____
_____	12.00	_____	x 5.290	= _____	_____	12.00	_____	x 6.348	= _____
_____	14.00	_____	x 22.095	= _____	_____	14.00	_____	x 20.098	= _____
_____	16.00	_____	x 44.952	= _____	_____	16.00	_____	x 43.454	= _____
_____	18.00	_____	x 69.070	= _____	_____	18.00	_____	x 67.598	= _____
_____	20.00	_____	x 93.004	= _____	_____	20.00	_____	x 91.560	= _____
_____	22.00	_____	x 85.305	= _____	_____	22.00	_____	x 84.245	= _____
_____	23.00	_____	x 47.646	= _____	_____	23.00	_____	x 47.122	= _____
_____	23.50	_____	x 25.067	= _____	_____	23.50	_____	x 33.265	= _____
_____	23.75	_____	x 17.173	= _____	_____	24.00	_____	x 25.911	= _____
_____	24.00	_____	x 17.540	= _____	_____	24.25	_____	x 17.735	= _____
_____	24.25	_____	x 17.906	= _____	_____	24.50	_____	x 18.102	= _____
_____	24.50	_____	x 18.273	= _____	_____	24.75	_____	x 18.468	= _____
_____	24.50	_____	x 32.863	= _____	_____	25.00	_____	x 33.206	= _____
_____			TOTAL	_____	_____			TOTAL	_____
TOTAL _____ ÷ 1016.61 = MEAN VEL _____					TOTAL _____ ÷ 1037.19 = MEAN VEL _____				

25.50 - 25.75

26.00 - 26.25

PIPE ID = 26.00"      # OF DATA POINTS 26					PIPE ID = 26.25"      # OF DATA POINTS 25				
REF (RD) DISTANCE	SENSOR LOCATION	MEASURED VELOCITY (FPS)	WEIGHT CONSTANT	WEIGHTED VELOCITY	REF (RD) DISTANCE	SENSOR LOCATION	MEASURED VELOCITY (FPS)	WEIGHT CONSTANT	WEIGHTED VELOCITY
_____	0.00	_____	x 44.928	= _____	_____	0.00	_____	x 45.370	= _____
_____	0.25	_____	x 19.322	= _____	_____	0.25	_____	x 19.518	= _____
_____	0.50	_____	x 18.921	= _____	_____	0.50	_____	x 19.118	= _____
_____	0.75	_____	x 18.521	= _____	_____	0.75	_____	x 18.717	= _____
_____	1.00	_____	x 27.034	= _____	_____	1.00	_____	x 27.329	= _____
_____	1.50	_____	x 34.643	= _____	_____	1.50	_____	x 35.037	= _____
_____	2.00	_____	x 48.986	= _____	_____	2.00	_____	x 49.576	= _____
_____	3.00	_____	x 59.733	= _____	_____	3.00	_____	x 60.520	= _____
_____	4.00	_____	x 77.749	= _____	_____	4.00	_____	x 78.929	= _____
_____	6.00	_____	x 81.549	= _____	_____	6.00	_____	x 83.120	= _____
_____	8.00	_____	x 56.494	= _____	_____	8.00	_____	x 58.058	= _____
_____	10.00	_____	x 31.616	= _____	_____	10.00	_____	x 33.170	= _____
_____	12.00	_____	x 7.503	= _____	_____	12.00	_____	x 8.756	= _____
_____	14.00	_____	x 18.194	= _____	_____	14.00	_____	x 16.384	= _____
_____	16.00	_____	x 41.954	= _____	_____	16.00	_____	x 40.451	= _____
_____	18.00	_____	x 66.122	= _____	_____	18.00	_____	x 64.643	= _____
_____	20.00	_____	x 90.112	= _____	_____	20.00	_____	x 88.660	= _____
_____	22.00	_____	x 83.181	= _____	_____	22.00	_____	x 82.113	= _____
_____	23.00	_____	x 46.597	= _____	_____	23.00	_____	x 62.180	= _____
_____	23.50	_____	x 32.917	= _____	_____	24.00	_____	x 50.501	= _____
_____	24.00	_____	x 25.652	= _____	_____	24.50	_____	x 26.496	= _____
_____	24.25	_____	x 17.563	= _____	_____	24.75	_____	x 18.126	= _____
_____	24.50	_____	x 17.930	= _____	_____	25.00	_____	x 18.493	= _____
_____	24.75	_____	x 18.297	= _____	_____	25.25	_____	x 18.860	= _____
_____	25.00	_____	x 18.664	= _____	_____	25.50	_____	x 33.892	= _____
_____	25.25	_____	x 33.549	= _____	_____			TOTAL _____	
_____			TOTAL _____		_____		TOTAL _____		
			TOTAL _____ ÷ 1057.95 = MEAN VEL _____				TOTAL _____ ÷ 1078.89 = MEAN VEL _____		

PIPE ID = 26.50"      # OF DATA POINTS 26					PIPE ID = 26.75"      # OF DATA POINTS 26				
REF (RD) DISTANCE	SENSOR LOCATION	MEASURED VELOCITY (FPS)	WEIGHT CONSTANT	WEIGHTED VELOCITY	REF (RD) DISTANCE	SENSOR LOCATION	MEASURED VELOCITY (FPS)	WEIGHT CONSTANT	WEIGHTED VELOCITY
_____	0.00	_____	x 45.812	= _____	_____	0.00	_____	x 46.254	= _____
_____	0.25	_____	x 19.715	= _____	_____	0.25	_____	x 19.911	= _____
_____	0.50	_____	x 19.314	= _____	_____	0.50	_____	x 19.511	= _____
_____	0.75	_____	x 18.914	= _____	_____	0.75	_____	x 19.111	= _____
_____	1.00	_____	x 27.624	= _____	_____	1.00	_____	x 27.919	= _____
_____	1.50	_____	x 35.431	= _____	_____	1.50	_____	x 35.824	= _____
_____	2.00	_____	x 50.167	= _____	_____	2.00	_____	x 50.757	= _____
_____	3.00	_____	x 61.308	= _____	_____	3.00	_____	x 62.095	= _____
_____	4.00	_____	x 80.110	= _____	_____	4.00	_____	x 81.290	= _____
_____	6.00	_____	x 84.692	= _____	_____	6.00	_____	x 86.263	= _____
_____	8.00	_____	x 59.622	= _____	_____	8.00	_____	x 61.187	= _____
_____	10.00	_____	x 34.724	= _____	_____	10.00	_____	x 36.279	= _____
_____	12.00	_____	x 10.105	= _____	_____	12.00	_____	x 11.551	= _____
_____	14.00	_____	x 14.668	= _____	_____	14.00	_____	x 13.045	= _____
_____	16.00	_____	x 38.946	= _____	_____	16.00	_____	x 37.438	= _____
_____	18.00	_____	x 63.160	= _____	_____	18.00	_____	x 61.675	= _____
_____	20.00	_____	x 87.204	= _____	_____	20.00	_____	x 85.745	= _____
_____	22.00	_____	x 81.041	= _____	_____	22.00	_____	x 79.966	= _____
_____	23.00	_____	x 61.475	= _____	_____	23.00	_____	x 60.767	= _____
_____	24.00	_____	x 49.978	= _____	_____	24.00	_____	x 49.452	= _____
_____	24.50	_____	x 26.236	= _____	_____	24.50	_____	x 34.822	= _____
_____	24.75	_____	x 17.953	= _____	_____	25.00	_____	x 27.081	= _____
_____	25.00	_____	x 18.321	= _____	_____	25.25	_____	x 18.516	= _____
_____	25.25	_____	x 18.688	= _____	_____	25.50	_____	x 18.884	= _____
_____	25.50	_____	x 19.055	= _____	_____	25.75	_____	x 19.251	= _____
_____	25.75	_____	x 34.235	= _____	_____	26.00	_____	x 34.579	= _____
_____			TOTAL _____		_____			TOTAL _____	
TOTAL _____ ÷ 1100.01 = MEAN VEL _____					TOTAL _____ ÷ 1121.31 = MEAN VEL _____				

26.50 - 26.75



27.00 - 27.25

PIPE ID = 27.00"      # OF DATA POINTS 27					PIPE ID = 27.25"      # OF DATA POINTS 25				
REF (RD) DISTANCE	SENSOR LOCATION	MEASURED VELOCITY (FPS)	WEIGHT CONSTANT	WEIGHTED VELOCITY	REF (RD) DISTANCE	SENSOR LOCATION	MEASURED VELOCITY (FPS)	WEIGHT CONSTANT	WEIGHTED VELOCITY
_____	0.00	_____	x 46.696	= _____	_____	0.00	_____	x 47.138	= _____
_____	0.25	_____	x 20.108	= _____	_____	0.25	_____	x 20.304	= _____
_____	0.50	_____	x 19.707	= _____	_____	0.50	_____	x 19.904	= _____
_____	0.75	_____	x 19.307	= _____	_____	0.75	_____	x 19.504	= _____
_____	1.00	_____	x 28.214	= _____	_____	1.00	_____	x 28.509	= _____
_____	1.50	_____	x 36.218	= _____	_____	1.50	_____	x 36.611	= _____
_____	2.00	_____	x 51.348	= _____	_____	2.00	_____	x 51.938	= _____
_____	3.00	_____	x 62.883	= _____	_____	3.00	_____	x 63.670	= _____
_____	4.00	_____	x 82.471	= _____	_____	4.00	_____	x 83.652	= _____
_____	6.00	_____	x 87.835	= _____	_____	6.00	_____	x 89.406	= _____
_____	8.00	_____	x 62.753	= _____	_____	8.00	_____	x 64.318	= _____
_____	10.00	_____	x 37.835	= _____	_____	10.00	_____	x 39.392	= _____
_____	12.00	_____	x 13.095	= _____	_____	12.00	_____	x 14.736	= _____
_____	14.00	_____	x 11.517	= _____	_____	14.00	_____	x 10.083	= _____
_____	16.00	_____	x 35.929	= _____	_____	16.00	_____	x 34.417	= _____
_____	18.00	_____	x 60.187	= _____	_____	18.00	_____	x 58.697	= _____
_____	20.00	_____	x 84.281	= _____	_____	20.00	_____	x 82.815	= _____
_____	22.00	_____	x 78.888	= _____	_____	22.00	_____	x 106.771	= _____
_____	23.00	_____	x 60.057	= _____	_____	24.00	_____	x 95.661	= _____
_____	24.00	_____	x 48.925	= _____	_____	25.00	_____	x 52.836	= _____
_____	24.50	_____	x 34.473	= _____	_____	25.50	_____	x 27.666	= _____
_____	25.00	_____	x 26.821	= _____	_____	25.75	_____	x 18.907	= _____
_____	25.25	_____	x 18.343	= _____	_____	26.00	_____	x 19.275	= _____
_____	25.50	_____	x 18.711	= _____	_____	26.25	_____	x 19.643	= _____
_____	25.75	_____	x 19.079	= _____	_____	26.50	_____	x 35.265	= _____
_____	26.00	_____	x 19.447	= _____	_____				
_____	26.25	_____	x 34.922	= _____	_____				
_____				TOTAL _____	_____				TOTAL _____
_____				TOTAL _____ ÷ 1142.78 = MEAN VEL _____	_____				TOTAL _____ ÷ 1164.43 = MEAN VEL _____

PIPE ID = 27.50" # OF DATA POINTS 26					PIPE ID = 27.75" # OF DATA POINTS 26				
REF (RD) DISTANCE	SENSOR LOCATION	MEASURED VELOCITY (FPS)	WEIGHT CONSTANT	WEIGHTED VELOCITY	REF (RD) DISTANCE	SENSOR LOCATION	MEASURED VELOCITY (FPS)	WEIGHT CONSTANT	WEIGHTED VELOCITY
_____	0.00	_____	x 47.580	= _____	_____	0.00	_____	x 48.022	= _____
_____	0.25	_____	x 20.501	= _____	_____	0.25	_____	x 20.697	= _____
_____	0.50	_____	x 20.100	= _____	_____	0.50	_____	x 20.297	= _____
_____	0.75	_____	x 19.700	= _____	_____	0.75	_____	x 19.897	= _____
_____	1.00	_____	x 28.804	= _____	_____	1.00	_____	x 29.099	= _____
_____	1.50	_____	x 37.005	= _____	_____	1.50	_____	x 37.398	= _____
_____	2.00	_____	x 52.528	= _____	_____	2.00	_____	x 53.119	= _____
_____	3.00	_____	x 64.458	= _____	_____	3.00	_____	x 65.245	= _____
_____	4.00	_____	x 84.832	= _____	_____	4.00	_____	x 86.013	= _____
_____	6.00	_____	x 90.978	= _____	_____	6.00	_____	x 92.550	= _____
_____	8.00	_____	x 65.884	= _____	_____	8.00	_____	x 67.451	= _____
_____	10.00	_____	x 40.949	= _____	_____	10.00	_____	x 42.507	= _____
_____	12.00	_____	x 16.474	= _____	_____	12.00	_____	x 18.310	= _____
_____	14.00	_____	x 8.744	= _____	_____	14.00	_____	x 7.500	= _____
_____	16.00	_____	x 32.903	= _____	_____	16.00	_____	x 31.388	= _____
_____	18.00	_____	x 57.203	= _____	_____	18.00	_____	x 55.708	= _____
_____	20.00	_____	x 81.345	= _____	_____	20.00	_____	x 79.872	= _____
_____	22.00	_____	x 105.328	= _____	_____	22.00	_____	x 103.880	= _____
_____	24.00	_____	x 94.598	= _____	_____	24.00	_____	x 93.532	= _____
_____	25.00	_____	x 52.311	= _____	_____	25.00	_____	x 51.784	= _____
_____	25.50	_____	x 27.405	= _____	_____	25.50	_____	x 36.380	= _____
_____	25.75	_____	x 18.733	= _____	_____	26.00	_____	x 28.252	= _____
_____	26.00	_____	x 19.102	= _____	_____	26.25	_____	x 19.298	= _____
_____	26.25	_____	x 19.471	= _____	_____	26.50	_____	x 19.666	= _____
_____	26.50	_____	x 19.839	= _____	_____	26.75	_____	x 20.034	= _____
_____	26.75	_____	x 35.608	= _____	_____	27.00	_____	x 35.951	= _____
_____			TOTAL _____		_____		TOTAL _____		
TOTAL _____ ÷ 1186.24 = MEAN VEL _____					TOTAL _____ ÷ 1208.23 = MEAN VEL _____				

27.50 - 27.75

28.00 - 28.25

PIPE ID = 28.00"      # OF DATA POINTS 27					PIPE ID = 28.25"      # OF DATA POINTS 26				
REF (RD) DISTANCE	SENSOR LOCATION	MEASURED VELOCITY (FPS)	WEIGHT CONSTANT	WEIGHTED VELOCITY	REF (RD) DISTANCE	SENSOR LOCATION	MEASURED VELOCITY (FPS)	WEIGHT CONSTANT	WEIGHTED VELOCITY
_____	0.00	_____	x 48.464	= _____	_____	0.00	_____	x 48.906	= _____
_____	0.25	_____	x 20.894	= _____	_____	0.25	_____	x 21.090	= _____
_____	0.50	_____	x 20.494	= _____	_____	0.50	_____	x 20.690	= _____
_____	0.75	_____	x 20.094	= _____	_____	0.75	_____	x 20.290	= _____
_____	1.00	_____	x 29.394	= _____	_____	1.00	_____	x 29.689	= _____
_____	1.50	_____	x 37.792	= _____	_____	1.50	_____	x 38.185	= _____
_____	2.00	_____	x 53.709	= _____	_____	2.00	_____	x 54.300	= _____
_____	3.00	_____	x 66.033	= _____	_____	3.00	_____	x 66.820	= _____
_____	4.00	_____	x 87.194	= _____	_____	4.00	_____	x 88.374	= _____
_____	6.00	_____	x 94.122	= _____	_____	6.00	_____	x 95.694	= _____
_____	8.00	_____	x 69.017	= _____	_____	8.00	_____	x 70.584	= _____
_____	10.00	_____	x 44.066	= _____	_____	10.00	_____	x 45.625	= _____
_____	12.00	_____	x 20.243	= _____	_____	12.00	_____	x 22.273	= _____
_____	14.00	_____	x 6.350	= _____	_____	14.00	_____	x 5.296	= _____
_____	16.00	_____	x 29.870	= _____	_____	16.00	_____	x 28.351	= _____
_____	18.00	_____	x 54.210	= _____	_____	18.00	_____	x 52.709	= _____
_____	20.00	_____	x 78.396	= _____	_____	20.00	_____	x 76.917	= _____
_____	22.00	_____	x 102.429	= _____	_____	22.00	_____	x 100.974	= _____
_____	24.00	_____	x 92.463	= _____	_____	24.00	_____	x 91.390	= _____
_____	25.00	_____	x 51.255	= _____	_____	25.00	_____	x 68.389	= _____
_____	25.50	_____	x 36.030	= _____	_____	26.00	_____	x 55.173	= _____
_____	26.00	_____	x 27.990	= _____	_____	26.50	_____	x 28.837	= _____
_____	26.25	_____	x 19.124	= _____	_____	26.75	_____	x 19.688	= _____
_____	26.50	_____	x 19.493	= _____	_____	27.00	_____	x 20.057	= _____
_____	26.75	_____	x 19.862	= _____	_____	27.25	_____	x 20.426	= _____
_____	27.00	_____	x 20.230	= _____	_____	27.50	_____	x 36.637	= _____
_____	27.25	_____	x 36.294	= _____	_____			TOTAL _____	
			TOTAL _____					TOTAL _____	
TOTAL _____ ÷ 1230.39 = MEAN VEL _____					TOTAL _____ ÷ 1252.70 = MEAN VEL _____				





28.00 - 28.25

PIPE ID = 29.50"      # OF DATA POINTS 27					PIPE ID = 29.75"      # OF DATA POINTS 27				
REF (RD) DISTANCE	SENSOR LOCATION	MEASURED VELOCITY (FPS)	WEIGHT CONSTANT	WEIGHTED VELOCITY	REF (RD) DISTANCE	SENSOR LOCATION	MEASURED VELOCITY (FPS)	WEIGHT CONSTANT	WEIGHTED VELOCITY
_____	0.00	_____	x 51.116	= _____	_____	0.00	_____	x 51.558	= _____
_____	0.25	_____	x 22.073	= _____	_____	0.25	_____	x 22.269	= _____
_____	0.50	_____	x 21.673	= _____	_____	0.50	_____	x 21.869	= _____
_____	0.75	_____	x 21.273	= _____	_____	0.75	_____	x 21.470	= _____
_____	1.00	_____	x 31.164	= _____	_____	1.00	_____	x 31.459	= _____
_____	1.50	_____	x 40.152	= _____	_____	1.50	_____	x 40.546	= _____
_____	2.00	_____	x 57.251	= _____	_____	2.00	_____	x 57.841	= _____
_____	3.00	_____	x 70.757	= _____	_____	3.00	_____	x 71.544	= _____
_____	4.00	_____	x 94.278	= _____	_____	4.00	_____	x 95.458	= _____
_____	6.00	_____	x 103.555	= _____	_____	6.00	_____	x 105.128	= _____
_____	8.00	_____	x 78.422	= _____	_____	8.00	_____	x 79.990	= _____
_____	10.00	_____	x 53.427	= _____	_____	10.00	_____	x 54.989	= _____
_____	12.00	_____	x 28.569	= _____	_____	12.00	_____	x 30.122	= _____
_____	14.00	_____	x 5.306	= _____	_____	14.00	_____	x 6.367	= _____
_____	16.00	_____	x 22.183	= _____	_____	16.00	_____	x 20.175	= _____
_____	18.00	_____	x 45.175	= _____	_____	18.00	_____	x 43.663	= _____
_____	20.00	_____	x 69.481	= _____	_____	20.00	_____	x 67.987	= _____
_____	22.00	_____	x 93.649	= _____	_____	22.00	_____	x 92.175	= _____
_____	24.00	_____	x 117.679	= _____	_____	24.00	_____	x 116.228	= _____
_____	26.00	_____	x 103.907	= _____	_____	26.00	_____	x 102.836	= _____
_____	27.00	_____	x 56.983	= _____	_____	27.00	_____	x 56.452	= _____
_____	27.50	_____	x 29.746	= _____	_____	27.50	_____	x 39.498	= _____
_____	27.75	_____	x 20.295	= _____	_____	28.00	_____	x 30.595	= _____
_____	28.00	_____	x 20.666	= _____	_____	28.25	_____	x 20.861	= _____
_____	28.25	_____	x 21.036	= _____	_____	28.50	_____	x 21.231	= _____
_____	28.50	_____	x 21.405	= _____	_____	28.75	_____	x 21.601	= _____
_____	28.75	_____	x 38.353	= _____	_____	29.00	_____	x 38.696	= _____
_____			TOTAL _____		_____			TOTAL _____	
TOTAL _____ ÷ 1366.70 = MEAN VEL _____					TOTAL _____ ÷ 1389.97 = MEAN VEL _____				

29.50 - 29.75

30.00

PIPE ID = 30.00"		# OF DATA POINTS 28		
REF (RD) DISTANCE	SENSOR LOCATION	MEASURED VELOCITY (FPS)	WEIGHT CONSTANT	WEIGHTED VELOCITY
_____	0.00	_____	x 52.000	= _____
_____	0.25	_____	x 22.466	= _____
_____	0.50	_____	x 22.066	= _____
_____	0.75	_____	x 21.666	= _____
_____	1.00	_____	x 31.754	= _____
_____	1.50	_____	x 40.939	= _____
_____	2.00	_____	x 58.432	= _____
_____	3.00	_____	x 72.331	= _____
_____	4.00	_____	x 96.639	= _____
_____	6.00	_____	x 106.701	= _____
_____	8.00	_____	x 81.559	= _____
_____	10.00	_____	x 56.551	= _____
_____	12.00	_____	x 31.676	= _____
_____	14.00	_____	x 7.524	= _____
_____	16.00	_____	x 18.262	= _____
_____	18.00	_____	x 42.148	= _____
_____	20.00	_____	x 66.490	= _____
_____	22.00	_____	x 90.698	= _____
_____	24.00	_____	x 114.773	= _____
_____	26.00	_____	x 01.762	= _____
_____	27.00	_____	x 55.920	= _____
_____	27.50	_____	x 39.146	= _____
_____	28.00	_____	x 30.331	= _____
_____	28.25	_____	x 20.686	= _____
_____	28.50	_____	x 21.057	= _____
_____	28.75	_____	x 21.427	= _____
_____	29.00	_____	x 21.797	= _____
_____	29.25	_____	x 39.040	= _____
_____			TOTAL	_____
TOTAL _____		÷ 1413.38 = MEAN VEL _____		

McCrometer, Inc. reserves the right to revise this publication and to make changes in its content without obligation to notify any person of such revision or changes.

FPI-Mag™ is a trademark of McCrometer, Inc.