

# Custody Transfer Measurement with the V-Cone Flowmeter

*Stephen A. Ifft  
McCrometer Inc.  
Hemet, California, USA*

## **Abstract**

This paper will discuss the approval of the McCrometer V-Cone flowmeter for custody transfer measurement in Canada. In May 1998, Measurement Canada issued AG-0428, the Notice of Approval for the V-Cone meter. This notice states the models and methods approved for use in Canada. Of particular note is the need for approved V-Cone calculation devices.

## **Introduction**

The V-Cone is a differential pressure flowmeter invented and manufactured by McCrometer Inc. Patented in 1986 as a new type of differential pressure flow meter, the V-Cone is based on the principles of Bernoulli.

The geometry of the V-Cone is a radically different approach to differential pressure flow metering, see Figure 1. As with other differential pressure devices, the flow constricts to create a high velocity area, which creates a lower pressure just past the constriction. By measuring the pressure upstream and downstream of the cone, a differential pressure is known and can be related to the flowrate through the pipeline. The V-Cone's constriction, however, is not a concentric opening through the center of the pipe like traditional differential pressure flowmeters. The V-Cone creates an annular opening, forcing the fluid to

flow around a cone positioned in the center of the pipe.

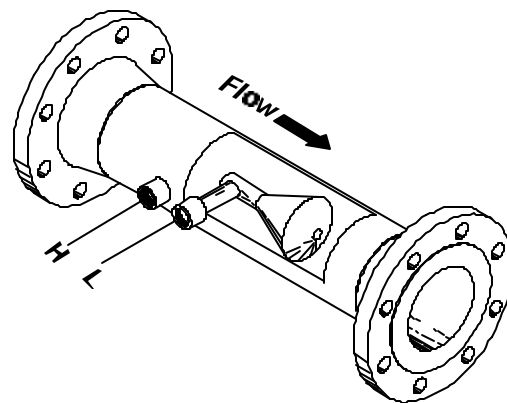

*Fig. 1 Illustration of a typical V-Cone design*

Equations for the V-Cone are only slightly different from standard differential pressure equations. The V-Cone beta ratio follows the same principle as other differential pressure devices. Thus a V-Cone and an orifice plate beta ratio are equivalent to each other in terms of open area. The basic equation of flow for the V-Cone is similar to standard differential pressure equations.

## **Approval Process**

The approval process with the Canadian government is well defined in documents such as the Specifications for Approval of Type of Gas Meters and Auxiliary Devices (LMB-EG-08). This

document states, among others, the requirements for approval of certain types of flowmeters. These meters are generally defined as:

1. Diaphragm meters           Section 5
2. Rotary meters               Section 6
3. Turbine meters             Section 7
4. Orifice meters             Section 8
5. Mass flow meters         Section 9

The V-Cone is a differential pressure type device and McCrometer's intention was to have the V-Cone certified under the same principles and requirements as an orifice plate.

After receiving the application for type approval for the V-Cone, Measurement Canada reviewed the product data and existing performance data regarding the V-Cone. Even though the V-Cone is based on the same principles as the orifice plate, the V-Cone could not be evaluated under the same requirements as the orifice meter's section.

Section 8 of the specifications refers extensively to the American National Standard, ANSI/API 2530, "Orifice Metering of Natural Gas and Other Related Hydrocarbon Fluids." This standard deals exclusively with the orifice plate design and could not be correlated to a V-Cone application. Measurement Canada then needed to decide how to deal with the V-Cone and under what section the evaluation should proceed.

For two apparent reasons, the V-Cone application would be evaluated under Section 7 of the specifications regarding turbine meters. The first reason was the performance specifications of the V-Cone. The standard accuracy and turndown of the V-Cone is stated as

$\pm 0.5\%$  of rate over a 10:1 turndown. The requirements for turbine meters under this section call for 1% of rate for the entire measurement system over a 10:1 flow turndown. A system accuracy of  $\pm 1\%$  of rate is easily possible with a combination of the V-Cone and the correct measurement and calculation equipment.

The second reason was the issue of calibration. Similar to turbine meters, V-Cone meters need in-line calibrations for the best accuracy. Each custody transfer V-Cone will be flow calibrated at a laboratory directly traceable to Canadian or American national measurement standards. These laboratories are typically independent companies whose expertise is in compressible gas flow and calibration.

### ***Performance Test***

A performance test is a necessary part of the evaluation process. Measurement Canada required a witnessed test of the performance of the meter and instrument system. This test would support the documented data already produced during the evaluation process.

A typical turbine meter calibration would take place in Measurement Canada's gas flow facility. This system operates at atmospheric pressure and was not suited for the higher-pressure performance test of the V-Cone. With consent from both Measurement Canada and McCrometer, the Colorado Engineering Experiment Station, Inc. (CEESI) was selected as the test laboratory for the performance test. CEESI is well acquainted with the V-Cone and well equipped for the type of calibration required.

McCrometer was to supply the V-Cone and the necessary instrumentation. Measurement Canada would witness and certify the test. An existing four-inch V-Cone with a beta ratio of 0.45 was selected. This size meter and cone would fit easily into the CEESI test lab and require only moderately high flowrates to generate a sufficient differential pressure. A Rosemount 3095MV was the secondary instrumentation chosen for the flow measurement system. The 3095MV, when programmed to work with the V-Cone, would output a 4-20 mA signal proportional to the mass flowrate through the meter. McCrometer chose a multivariable transmitter to simplify the verification of the flow calculations.

CEESI's laboratory is referenced using critical flow venturi nozzles. These nozzles and the entire instrumentation system are completely traceable to the U.S. National Institute of Standards and Technology. A large volume of high-pressure air supplies the test system. The system vents air back to atmosphere a sufficient distance downstream of the test section.

The results of the test indicate performance well within the required specifications for Measurement Canada. See Appendices A & B for tabular and graphical results. Absolute pressure during the test was approximately 200 psia and covered a Reynolds number range of approximately 1 million to 75,000. Over this flow range of 13:1, the system accuracy of the V-Cone and Rosemount 3095MV was +0.30 to -0.54% of rate. By adjusting the flow coefficient according to the calibration, the system accuracy could be stated as  $\pm 0.42\%$  of rate. This exceeds the

specifications of the V-Cone primary element. When considering the added uncertainty of the instrumentation and flow calculations, this test shows very good performance.

#### ***Notice of Approval***

Following the performance tests, several drafts of the notice of approval were reviewed. After the review and translation of the document were complete, the final Notice of Approval (NOA) was granted March 19, 1998. The notice states "*The V-Cone meter is a differential pressure type flowmeter approved for custody transfer of natural gas.*"

Certain model numbers were approved for the custody transfer measurements. The approved models are the VR and VW. The VR denotes ANSI weld neck, ring type joint flanges. The VW denotes ANSI weld neck, raised face flanges. Both models were approved from pressure class 150 to 900. Acceptable sizes range from 1/2" to 36". Allowable materials of construction for the meter are carbon steel, stainless steel, and Duplex 2205.

Following the guidelines of Section 7 of the specifications, the installation requirements must be in accordance with McCrometer's recommendations. The markings on any Canadian custody transfer V-Cone must include certain information, including the departmental approval number.

Also following Section 7, the V-Cone must be verified either in-situ or at "*a high pressure gas meter calibration facility acceptable to Industry Canada.*" CEESI and other laboratories are available for this testing if necessary.

The NOA states *“This V-Cone meter uses any approved and compatible flow transmitter or flow computer that is approved to perform V-Cone meter calculations for determining the volume of gas through the meter at standard conditions.”* This sentence refers to the method of calculation used to determine mass flowrate of gas through the meter. Two methods are currently being used by the natural gas industry. This author will label these methods “traditional” and “multivariable”.

Both methods utilize the same basic principles. As displayed in Fig. 2, the measurements take place separately from the calculations. The measurements are also split between the primary element measurement, in this case the V-Cone, and the secondary measurements of differential pressure, pressure and temperature.

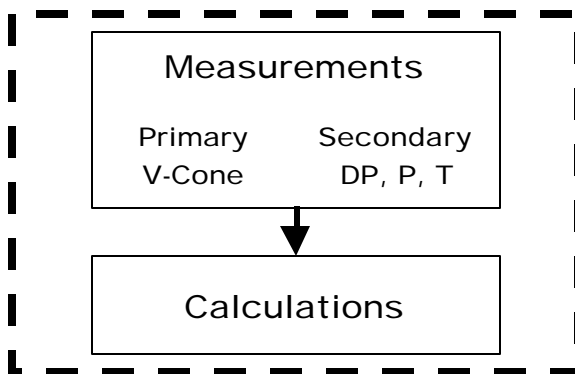

*Fig. 2 Basic differential pressure flow measurement system*

In traditional calculation methods, the measurements are done separately from the calculations. Transmitters would be used for the measurements of differential pressure, pressure, and temperature. Signals from these transmitters would be sent to a flow computer or a distributed control system (DCS). The flow calculations would be done separately

from the measurement area and displayed and used in various ways.

A relatively new method of flow calculation is now being accepted in the natural gas industry. The multivariable method uses a single instrument to measure differential pressure, pressure and temperature. This reduces the instruments and pipeline connections necessary in the differential pressure flow meter. The multivariable system uses these inputs and calculates the flow in the same instrument. This blurs the line between the measurement and calculation areas.

The NOA calls for “approved” devices to calculate the flow through a V-Cone. Currently no flow transmitters or flow computers are approved for use with the V-Cone. McCrometer is currently working with Measurement Canada to define the approval process for V-Cone calculation devices. Since the V-Cone is based on the same principles as traditional differential pressure devices and uses virtually the same mass flow equations as a venturi, this process should go rapidly. Several manufacturers of flow transmitters and flow computers have already incorporated the V-Cone into their devices. The Measurement Canada approvals for these devices will need only updating to show the current changes.

The option available to users at time of printing is the use of a DCS system. A DCS could be programmed to correctly calculate mass flow rate through a V-Cone, similarly to what is done for orifice plates. These systems must be individually approved through Measurement Canada.

### ***Conclusions***

The McCrometer V-Cone meter has been approved for custody transfer measurement of natural gas in Canada. The V-Cone performed above the requirements given by Measurement Canada.

This approval is significant for the V-Cone and will have impact well beyond Canada or even North America. The Measurement Canada approval process is the only government-based process in North America. The United States government does not provide this service. Independent organizations such as the American Gas Association (AGA) and the American Petroleum Institute (API) are expected to provide such standards and guidelines. The “approval process” through these organizations is not clearly defined, since the standards deal with meter design rather than performance. A patented meter design such as the V-Cone could not be covered with such a design standard. This may be changing as ultrasonic technology is entering the industry. Ultrasonic meters, while all use the same basic principles, have proprietary designs. Current drafts of standards within AGA and API deal with design and performance issues in different ways.

The impact of this approval has already been noticed in Canada and worldwide. Canadian users recognize the importance of this approval and have opened previously closed doors to the V-Cone technology. Users in the United States acknowledge the importance of the only approval process in North America. This author has been asked about this approval in places as far away as Australia and Norway.

McCrometer wishes to express thanks to the government workers of Measurement Canada for their fine and diligent work, particularly Randy Byrtus and Andy Kaulins.

### ***References***

1. Specifications for Approval of Type of Gas Meters and Auxiliary Devices (LMB-EG-08), Consumer and Corporate Affairs Canada, Legal Metrology Branch, 1987.
2. Notice of Approval, V-Cone Meter (AG-0428), Measurement Canada, March 19, 1998.

## Appendix A

### COLORADO ENGINEERING EXPERIMENT STATION, INC.

#### Calibration of a McCrometer V-Cone

Model: V5104 Serial No. 97042300

For: McCrometer Order:

Data File: 97MCC022 Disc: 0997-018 Date: 24 September 1997

Inlet diameter: 4.09 inches Throat diameter: 3.659 inches

Test gas: AIR Standard density= .074915 lbm/cu-ft

at standard conditions of 529.69 deg R, and 14.696 psia

Mtr Read: Meter reading in volts DC across a 99.995 ohms resistor

Mdot: Mass flowrate in Lbm/sec

Rey No: Inlet (pipe) Reynolds number

Mtr Read2: Meter reading in Lbm/sec

L	Mtr Read	Mdot	Rey No	Mtr Read 2
1	2.04827	3.107034	979671.9	3.0903
2	1.96022	2.937754	929007.2	2.9252
3	1.877705	2.784982	882329.4	2.7705
4	1.988706	2.992303	949333.8	2.9786
5	1.83909	2.711715	861650.7	2.6981
6	1.736693	2.51872	801073.4	2.5061
7	1.62633	2.304196	733300.8	2.2992
8	1.75828	2.560127	815130.8	2.5466
9	1.486764	2.038151	649239.9	2.0375
10	1.315351	1.717084	546966.2	1.7162
11	1.473358	2.010799	640427.2	2.0124
12	1.101089	1.317516	419555.6	1.3144
13	0.985557	1.100524	350291.8	1.0978
14	1.089277	1.294442	411758.4	1.2923
15	0.841574	0.830255	263978.5	0.8279
16	0.709143	0.581577	184854.3	0.5796
17	0.62474	0.421559	128848.2	0.4213
18	0.599846	0.375346	119100.3	0.3747
19	0.683298	0.531777	164978.3	0.5311
20	0.61198	0.398872	123801.4	0.3974
21	0.578701	0.334258	103731.1	0.3350
22	0.54688	0.27452	85167.09	0.2753
23	0.528939	0.241366	74870.05	0.2417
24	0.554899	0.28954	89840.09	0.2904

Average values for above results:

Press: 204.53 psia Density: 1.0919 lbm/cu-ft

Temp: 508.89 Deg R Viscosity: .00000098726 lbm/inch-sec

Compressibility factor: .99379

## Appendix B CEESI Calibration for Industry Canada Evaluation

4" V-Cone Beta 0.45 System Accuracy

