

PARTIALLY CLOSED VALVE EFFECTS ON THE V-CONE FLOWMETER

Stephen A. Ifft
(McCrometer Inc., Hemet, CA 92545, USA)

ABSTRACT

Research conducted from 1992 through 1996 indicates that the V-Cone flowmeter is less susceptible to upstream flow disturbances than traditional flowmeters. This previous testing by McCrometer and independent test facilities has placed various flow disturbances upstream of the V-Cone including single elbows, double elbows out-of-plane, valves, and swirl generators. In an effort to further quantify the effects of partially closed valves on the V-Cone, McCrometer has completed the first in a series of valve installation effects tests. This test program involves 50 millimeter V-Cone flowmeters, various beta ratios, and both butterfly and gate valve types. In each case, the V-Cone was tested downstream and upstream of the valves. All testing was completed at the McCrometer water test facility. This data will allow McCrometer to better specify the installation of V-Cones in certain applications near valves. The testing indicates the valves can have little effect on the V-Cone. With the valves upstream, the V-Cone performed accurately under all but the most extreme conditions, such as a butterfly valve closed 55% directly upstream. With the valves downstream, the V-Cone accuracy has not been affected by the location or angle of the valves.

INTRODUCTION

1. THE V-CONE FLOWMETER

McCrometer introduced the V-Cone flowmeter in 1986 as an alternative to traditional differential pressure flowmeters. The goal in the development of this device was to create a meter that emphasized the advantages, but overcame the limitations, associated with traditional differential pressure flowmeters. McCrometer holds patents on the V-Cone in the United States and worldwide.

The geometry of the V-Cone is a radically different approach to differential pressure flowmetering, see Figure 1. As with other differential pressure devices, the flow constricts to create high and low velocity areas, which creates a differential pressure signal. However, the V-Cone's constriction is not a concentric opening through the center of the pipe. The V-Cone creates an annular opening, forcing the fluid to flow around a cone positioned in the center of the pipe.

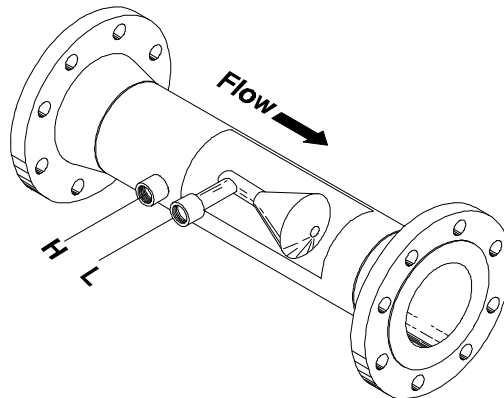

Fig. 1 Illustration of a typical V-Cone design

Equations for the V-Cone are only slightly different from standard differential pressure equations. The V-Cone beta ratio follows the same principle as other differential pressure devices. Thus a V-Cone and an orifice plate beta ratio are equivalent to each

other in terms of open area. The basic equation of flow for the V-Cone is similar to standard differential pressure equations.

2. PREVIOUS TESTING

Previous testing proved that the V-Cone is less sensitive to upstream flow disturbances than most traditional flowmeters. The first installation effects study tested three V-Cones downstream of a long radius single elbow and two long radius elbows out-of-plane¹. This testing was completed at McCrometer in 1992 using the same test apparatus as the current test program. The three test meters had beta ratios from 0.35 to 0.75. The results showed that all three V-Cones could be installed adjacent to either single elbows or double elbows out-of-plane without effecting accuracy.

McCrometer sponsored a series of testing at the Southwest Research institute in 1994². This series was intended to study the effects of a single elbow on a 100 mm V-Cone, beta ratio 0.67, using dry nitrogen gas as the test fluid. The conclusions from this study indicated again that the V-Cone can be closed coupled to a single elbow without effecting accuracy. A fully open plug valve was also placed between the single elbow and the V-Cone. The asymmetric opening of the plug valve did not effect the V-Cone.

Several independent papers have been published at the North Sea Flow Measurement Workshop. In 1994, Phillips Petroleum reported on a lengthy program using 75 mm and 100 mm V-Cones³. As part of the complete test program, the installation effects of the meters were tested downstream of a 180° bend and a partially closed valve. This paper concluded "uneven profile and swirl effect was not detected." Another workshop paper was jointly published in 1995 by Chevron Petroleum Technology Co., USA and K-Lab/Statoil, Norway⁴. Chevron tested three V-Cone meters with various beta ratios in swirling flow at low pressures and velocities. K-Lab, using the same meters, tested at high pressures and velocities. The report concluded that "Swirling flow seems to have little effect on V-Cone meter measurements. For swirler blade angles up to 40 degrees, the V-Cone meter measurements generally deviated within ±0.5% from the no-swirl baseline measurements."

To further define the installation requirements for a V-Cone, McCrometer decided to begin a series of tests to verify the performance of various V-Cones near fully open and partially closed valves. This paper reports on the first stage testing of the program. The American Gas Association's Report No.3-Part 2 specifies the installation requirements for orifice plate flowmeters for the U.S. natural gas market⁵. The installation requirements for an orifice meter placed downstream of a partially closed valve range from 16 to 45 diameters, for beta ratios from 0.1 to 0.75 respectively. This specification can be used as a reference for the performance of V-Cones downstream of partially closed valves.

EXPERIMENTAL

1. TEST APPARATUS

The McCrometer static gravimetric flow calibration stand can test 12 mm to 100 mm nominal diameter flowmeters in water.

The closed system recirculates water constantly from a 2200 liter storage tank. An electric pump draws the flow from the tank through a 100 mm PVC pipe. From the pump, the water enters an upstream header. The 250 mm by 1200 mm chamber incorporates straightening vanes and a dampening screen to lessen pulsations from the pump. A recirculating by-pass line of 50 mm PVC pipe also helps to reduce pulsations. The water leaves the header horizontally through 50 mm pipe into the test section.

The water passes through 50 D of straight 50 mm pipe before entering test section. Test section piping is schedule 40 stainless steel. The differential pressure taps on the

meters are horizontal to prevent air from entering the gage lines after purging. An appropriate range of differential pressure transmitters measures the produced signal from the V-Cone.

After passing the test section, the water enters three flow regulating valves and then the diverter section. A pneumatic system diverts the water to either a receiving tank, open directly to the storage tank, or to a collection tank. The collection tank weighs the collected water over a measured time. A proximity sensor on the diverter triggers a timer to measure the precise time of the collection period. A mercury thermometer measures the fluid temperature when the water is drained to the storage tank.

The electronic signal from the differential pressure transmitter is read through an analog to digital converter card in the laboratory computer. The 16-bit card is triggered with the start and stop of the collection period of the diverter.

Prior to testing, each piece of equipment was calibrated to traceable measurements from United States national standards at the National Institute of Standards and Technology.

2. TEST PROGRAM

The intention of this test program was to test the effects of fully open and partially closed valves placed near V-Cone flowmeters.

Two common types of valves were chosen for the testing, a butterfly valve and a gate valve. The test program placed the valves in three different locations in relation to the V-Cone under test. Locations upstream of the meter were at 0 and 3 nominal diameters and one location downstream at 0 diameters. These dimensions refer to the relative distance from the face of the valve body to the face of the V-Cone body flange. Therefore, 0 diameters represents the valve directly adjacent to the meter.

V-Cone meters have a standard beta ratio range from 0.45 to 0.85. As described above, the beta ratio for a V-Cone represents the same open area in the meter as traditional differential pressure flowmeters. Thus, a beta of 0.45 represents a large cone in relation to the pipe, and a beta of 0.85 represents a small cone. For this test, two V-Cones were chosen with beta ratios of 0.50 and 0.75. This range covers a wide portion of the standard beta ratio range for the V-Cone and encompasses the most widely used beta ratios in service.

Many variables need to be tested to quantify the installation effects of valve on a meter. This test program attempted to separate some of those variables to define the effect of each. The variables we sought to identify are listed below:

1. Beta ratio and differential pressure
2. Valve type
3. Valve location in relation to the meter
4. Valve orientation in relation to the taps on the meter
5. Valve percentage closed
6. Reynolds number

Other variables that could effect the performance of the V-Cone near valves are:

1. Line size
2. Line size in relation to meter length
3. Valve size and proportional blockage
4. Compressible gas effects

These variables will be studied with future testing programs.

Table 1 below shows the flowrates, differential pressures, and Reynolds numbers for each meter in the test program.

Table 1 Test program ranges of flowrates, differential pressure and Reynolds number.

Beta ratio	Flowrates (l/s)	Differential pressure (kPa)	Reynolds number
0.50	5	54	140000
	3.8	29	100000
	2	9.5	60000
0.75	5	8.7	140000
	3.8	5	100000
	2	1.6	60000

Table 2 presents all the possible configurations in relation to beta ratio, valve stem orientation, valve location, and valve type. Those with ✓'s have been tested in this test program.

Table 2 Test program matrix showing configurations tested.

	Inline with taps		90° to taps		Inline with taps		90° to taps	
	0 D US	3 D US	0 D US	3 D US	0 D DS		0 D DS	
$\beta = 0.5$								
BFV			✓					✓
GV	✓		✓			✓		
$\beta = 0.75$								
BFV	✓	✓	✓			✓		
GV	✓		✓	✓				
Notes: BFV = Butterfly valve, GV = Gate valve, D = nominal pipe diameter, US = upstream, DS = downstream.								

RESULTS AND DISCUSSION

The test program results are shown in the figures below. The figures show graphically the results on a plot of "%Change in C_f " vs. "Reynolds number". The C_f , or flow coefficient, is the equivalent to the dimensionless discharge coefficient of other differential pressure flowmeters. This coefficient characterizes the performance of a flowmeter under certain conditions. If the coefficient is unchanged under differing conditions, the meter will remain accurate to the original calibration. The term C_f is used with the V-Cone to indicate the coefficient is a calibrated value, not a calculated (uncalibrated) value. Reynolds number is also a dimensionless number and is used to define the characteristics of flow under certain conditions. McCrometer uses the Reynolds number when calibrating V-Cones. With this method, the Reynolds number of the intended application is matched using water or air with the calibration stand. The notation "Taps 90° to valve stem" indicates the orientation of the valve stem was vertical, while the differential pressure taps were horizontal. The notation "Taps inline with valve stem" indicated both the valve stem and the taps were horizontal.

Figures 2, 3, and 4 present results from testing the beta 0.5 V-Cone meter. A complete battery of test configurations was not feasible, so testing was abbreviated if further testing could not show more definition. For example, a gate valve placed at 0 diameters upstream of a meter effected the meter performance by less than ±0.5% from 0% to 50% closed. More testing, with the gate valve 3 diameters away, could not significantly improve the installation requirements for this application.

Figures 5, 6, and 7 present results from testing the beta 0.75 V-Cone meter. Again, the test program was abbreviated.

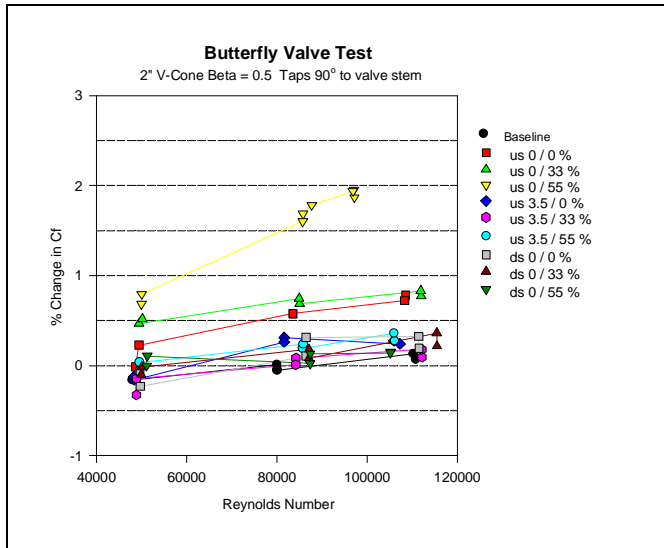

Fig. 2 Test results for beta 0.5 with taps 90° to the butterfly valve stem

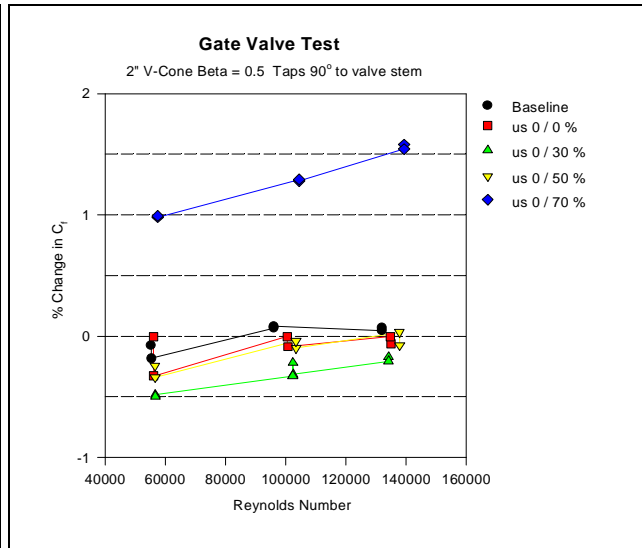

Fig. 3 Test results for beta 0.5 with taps 90° to the gate valve stem

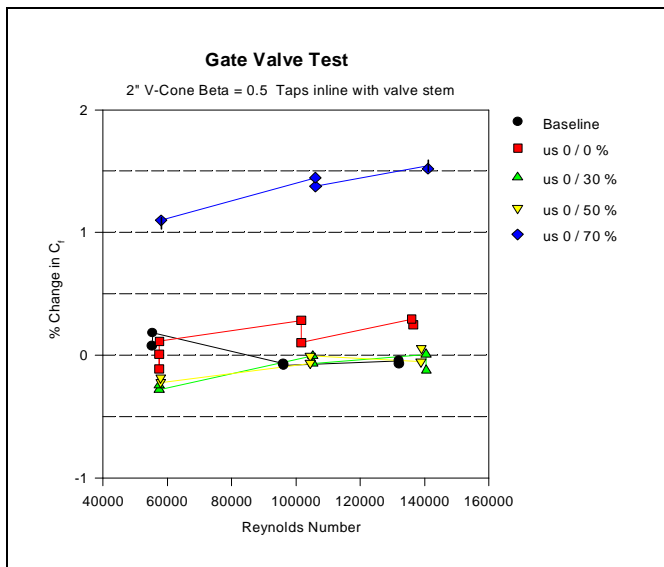

Fig. 4 Test results for beta 0.5 with taps inline with the gate valve stem

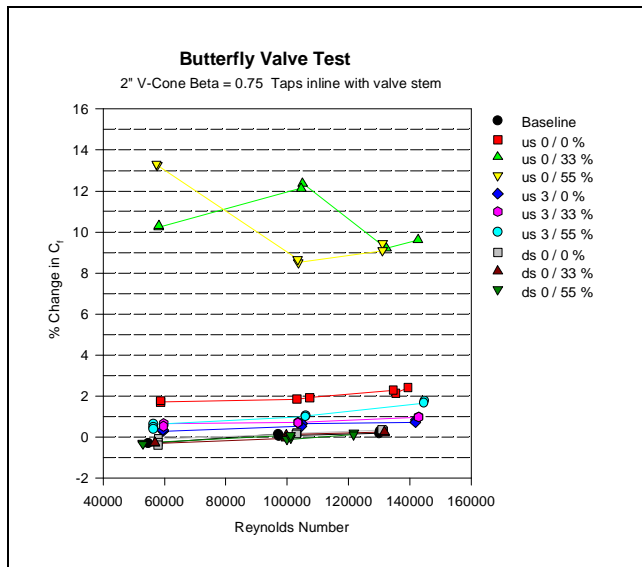

Fig. 5 Test results for beta 0.75 with taps inline with the butterfly valve stem

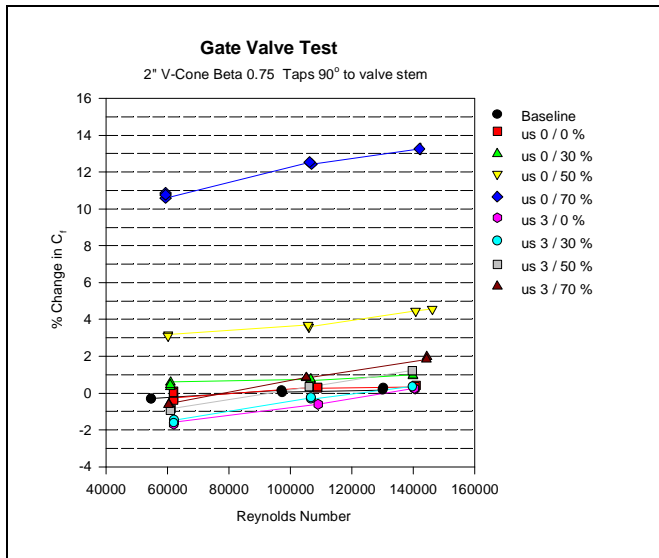

Fig. 6 Test results for beta 0.75 with taps 90° to the gate valve stem

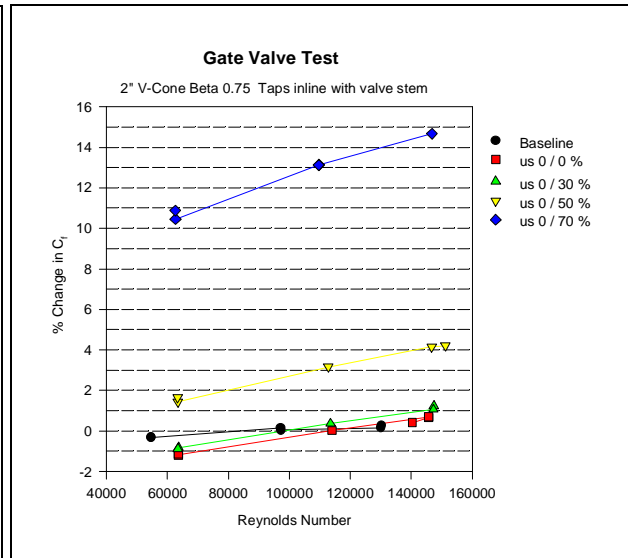

Fig. 7 Test results for beta 0.75 with taps inline with the gate valve stem

The following conclusions can be made from the testing data:

1. The following conditions are acceptable installations for standard V-Cone performance of $\pm 0.5\%$ of rate measurement:
 - With a 0.5 beta ratio, a gate valve can be placed adjacent to the meter and closed from 0 to 50%.
 - With a 0.5 beta ratio, a butterfly valve can be placed at 3 diameters upstream of the meter and closed from 0 to 55%.
 - With a 0.75 beta ratio, a gate valve can be placed adjacent to the meter and left fully open.
2. The following conditions are acceptable installations for applications where an additional $\pm 0.5\%$ of rate uncertainty is acceptable:
 - With a 0.5 beta ratio, a butterfly valve can be placed adjacent to the meter and closed 0 to 33%.
 - With a 0.75 beta ratio, a gate valve can be placed adjacent to the meter and closed 0 to 30%.
 - With a 0.75 beta ratio, a butterfly valve can be placed 3 diameters upstream of the meter and closed 0 to 33%.
3. No configurations tested with the 0.5 beta ratio V-Cone created changes in the C_f of greater than 2%.
4. No configuration with the valves 3 diameters upstream of the 0.75 beta ratio V-Cone created changes in the C_f of greater than 2%.
5. Beta ratio affects the installation requirements for the V-Cone under some severe conditions. This is the first series of tests that shows a dependence on beta ratio concerning installation requirements. The level of differential pressure is not believed to affect installation requirements.
6. The gate valve generally affected the performance of the meters less than the butterfly valve. For a 50 mm butterfly valve, the valve assembly takes up a large proportion of the open pipe area. A proportional study of larger line sizes may prove that butterfly valves do not consistently have a greater effect than gate valves.
7. Valves placed downstream of the V-Cones made no change in the performance of the meters. For both the beta ratios, using a butterfly valve adjacent to the meter did not affect the C_f .
8. Valve orientation effects were not detected. For both beta ratios, the orientation of the valve did not make a noticeable change in the performance of the meter. Two other valve orientations are possible at -90° and 180° , but the effect from these positions will likely be negligible.
9. Changes in the flow coefficient generally shifted to the positive. This indicates a drop in the expected differential pressure at the meter. The cause of these

increases is likely due to jetting through the valve. A jetting past the high pressure port would decrease the high pressure reading and lower the measured differential pressure. The minimal shifts in the C_f indicate the V-Cone is less sensitive to this kind of jetting than other meters due to the upstream flow conditioning ability of the meter itself.

10. Changes in the flow coefficient of the meters increased slightly with increasing Reynolds number. This does not necessarily apply to higher Reynolds numbers in compressible gasses.

SUMMARY

These series of tests support McCrometer's specifications that the V-Cone is less sensitive to upstream installation effects than traditional flow meters. Typical upstream installation requirements for the V-Cone are 0 to 3 diameters. The effect of the valves upstream of the two V-Cones was negligible at 0 diameters in some configurations and minimal in nearly all configurations at 3 diameters. It appears that standard V-Cone upstream piping requirements can be applied to most applications with partially closed valves. These tests also show that accurate measurements can be made with the V-Cone without the need for a flow conditioner installed between the valve and the meter. Zero to three diameter requirements are minor in comparison to AGA's requirements of sixteen to forty-five diameters⁵.

With the valve directly downstream of the meter, the effects were negligible. Typically downstream requirements for the V-Cone are 3 to 5 diameters. These requirements may be too conservative in light of these results.

More testing is required to fully understand the effects of fully open and partially closed valves upstream of V-Cone flowmeters. Future testing should include intermediate beta ratios to define the relationship of beta ratio and installation requirements. Larger line sizes should be included to gauge the effect of proportional differences. The effect of valves in compressible gas applications should also be explored. Other types of valves may be incorporated based on industry response.

REFERENCES

1. Ifft, S. A. and Mikkelsen, E. D., "Pipe Elbow Effects on the V-Cone Flowmeter." North Sea Flow Measurement Workshop, Peebles, Scotland, 1992.
2. Astleford, W. J., "Baseline and Installation Effects Tests of the V-Cone Meter." MRF Report No. 94-3, Southwest Research Institute, July 1994.
3. Dahlstrøm, M. J., "V-Cone Meter: Gas Measurement for the Real World." North Sea Flow Measurement Workshop, Peebles, Scotland, 1994.
4. Shen, J. S. and Bosio, J., "A Performance Study of a V-Cone Meter in Swirling Flow." North Sea Flow Measurement Workshop, Peebles, Scotland, 1995.
5. American Gas Association, "Orifice Metering of Natural Gas and Other Related Hydrocarbon Fluids" Report No. 3, Third Edition, October 1990.